



SERIES B

Follow us on



FLUID CARRYING LINE REPAIR SPECIALISTS

PROBLEM SOLVING AUTOMOTIVE HARDWARE

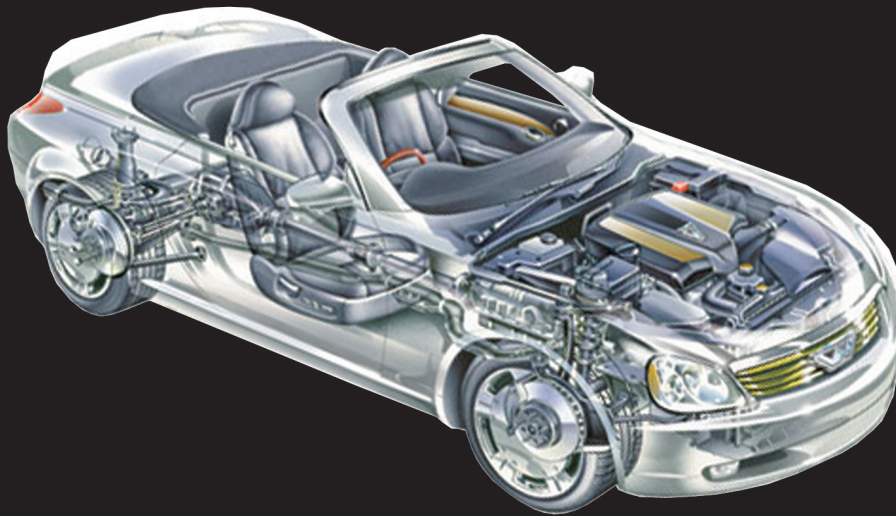

INDEX

BRAKE

1-5

BRASS HARDWARE

6-8

FUEL REPAIR

9-15

TRANSMISSION

16-17

POWER STEERING

18

DRAIN PLUGS

19-20

DOOR PIN KITS

21

CUTTING TIPS

22

TOOLS

23-24

AIR CONDITIONING

25-34

ASSORTMENTS

35-38

1070 HERITAGE ROAD, BURLINGTON, ONTARIO CANADA • L7L 4X9
ORDER DESK: 800-651-7445 • FAX : 905-335-1829
INFO@FMSIINC.COM • WWW.FMSIINC.COM



fmsi Automotive Hardware



fmsiAuto



CANADIAN MADE BRAKE LINES



Cupro Nickel: ★ ★ ★ ★ ★

The Ultimate brake line, guaranteed for the life of the vehicle.
Easiest to bend and flare, used Original Equipment by Volvo, Mercedes.

Poly Vinyl Fluoride: ★ ★ ★ ★

Polymer coated brake line that prevents corrosion and damage from stones and road debris.

Passivated Green: ★ ★ ★

Mid-range brake line with a green zinc coating, preventing damage from the elements.

Armored Zinc: ★ ★

Zinc plated brake line with added protection of galvanized wire armor to prevent road damage from stones and debris.

Standard Zinc: ★ ★

Zinc plated brake line, with burst pressures exceeding the SAE standard of 16,000 psi.



Floor Merchandiser
022-284



Wall Rack Display
0084

Also Available

- 0091 12 Slot Wall Rack
5/16" & 3/8"
- 0100 28 Slot Metric Wall Rack
- 0101 25 Slot Wall Rack
3/16", 1/4", 5/16" & 3/8"

Brake Line Coils

Overall length	Cupro Nickel Coils	Poly Vinyl Fluoride Coils	Passivated Green Coils	Standard Double Wall Zinc Coils
3/16"x 25'	CN3	PVF3	P3	C3
3/16"x 50'	CN3-50	PVF3-50	P3-50	C3-50
3/16"x 100'	CN3-100	PVF3-100	P3-100	C3-100
1/4"x 25'	CN4	PVF4	P4	C4
1/4"x 50'	CN4-50	PVF4-50	P4-50	C4-50
1/4"x 100'	CN4-100	PVF4-100	P4-100	C4-100
5/16"x 25'	CN5	PVF5	P5	C5
3/8"x 25'	CN6	PVF6	P6	C6



Fitted Brake Line Coils

Single end flare and fitting

Poly Vinyl Fluoride Coils	Standard Double Wall Zinc Coils
PVF3FITT	C3FITT
PVF4FITT	C4FITT
PVF5FITT	C5FITT
PVF6FITT	C6FITT

Cupro Nickel: ★ ★ ★ ★ ★

Overall length	3/16" O.D. (Union 3002) 5 per tube	1/4" O.D. (Union 3005) 5 per tube	Euro & Domestic (Union 3044) 5 per tube	Japanese (Union 3059) 5 per tube
8"	CN308	CN408	CNKMB8	CNKM8
12"	CN312	CN412	CNKMB12	CNKM12
20"	CN320	CN420	CNKMB20	CNKM20
30"	CN330	CN430	CNKMB30	CNKM30
40"	CN340	CN440	CNKMB40	CNKM40
51"	CN351	CN451	CNKMB51	CNKM51
60"	CN360	CN460	CNKMB60	CNKM60
72"	CN372	CN472	CNKMB72	CNKM72

- Original Equipment quality
- Best protection from corrosion
- Guaranteed for life



Poly Vinyl Fluoride: ★ ★ ★ ★

Overall length	3/16" O.D. (Union 3002) 10 per tube	1/4" O.D. (Union 3005) 10 per tube	5/16" O.D. (Union 3007) 5 per tube	3/8" O.D. (Union 3018) 5 per tube	Euro & Domestic (Union 3044) 5 per tube	Japanese (Union 3059) 5 per tube	Toyota / GM (Union 3059) 5 per tube	British / U.S. (Union 3047) 5 per tube	Six Millimeter (Union 4238) 5 per tube	GM Long Nut (Union 3044) 5 per tube
8"	PVF308	PVF408	PVF508	PVF608	PVFKMB8	PVFKM8	PVFKGM8	PVFKB8	PVF61208	PVFXL8
12"	PVF312	PVF412	PVF512	PVF612	PVFKMB12	PVFKM12	PVFKGM12	PVFKB12	PVF61212	PVFXL12
20"	PVF320	PVF420	PVF520	PVF620	PVFKMB20	PVFKM20	PVFKGM20	PVFKB20	PVF61220	PVFXL20
30"	PVF330	PVF430	PVF530	PVF630	PVFKMB30	PVFKM30	PVFKGM30	PVFKB30	PVF61230	PVFXL30
40"	PVF340	PVF440	PVF540	PVF640	PVFKMB40	PVFKM40	PVFKGM40	PVFKB40	PVF61240	PVFXL40
51"	PVF351	PVF451	PVF551	PVF651	PVFKMB51	PVFKM51	PVFKGM51	PVFKB51	PVF61251	PVFXL51
60"	PVF360	PVF460	PVF560	PVF660	PVFKMB60	PVFKM60	PVFKGM60	PVFKB60	PVF61260	PVFXL60
72"	PVF372	PVF472	PVF572	PVF672	PVFKMB72	PVFKM72	PVFKGM72	PVFKB72	PVF61272	PVFXL72
84"	-	-	-	-	PVFKMB84	PVFKM84	-	-	-	PVFXL84

SAE (STANDARD) & ISO (BUBBLE) FLARE

STANDARD

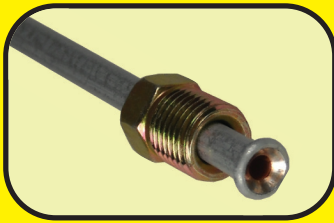

EURO / DOMESTIC

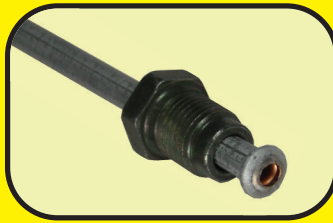

JAPANESE



TOYOTA / GM



BRITISH / US THREAD



SIX MILLIMETER

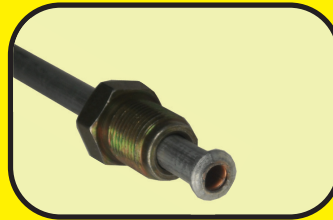

GM LONG NUT



Passivated Green: ★ ★ ★

Overall length	3/16" O.D. (Union 3002) 10 per tube	1/4" O.D. (Union 3005) 10 per tube	5/16" O.D. (Union 3007) 5 per tube	3/8" O.D. (Union 3018) 5 per tube	Euro & Domestic (Union 3044) 5 per tube	Japanese (Union 3059) 5 per tube	Toyota / GM (Union 3059) 5 per tube	British / U.S. (Union 3047) 5 per tube	Six Millimeter (Union 4238) 5 per tube	GM Long Nut (Union 3044) 5 per tube
8"	P308	P408	P508	P608	PKMB8	PKM8	PKGM8	PKB8	P61208	PXL8
12"	P312	P412	P512	P612	PKMB12	PKM12	PKGM12	PKB12	P61212	PXL12
20"	P320	P420	P520	P620	PKMB20	PKM20	PKGM20	PKB20	P61220	PXL20
30"	P330	P430	P530	P630	PKMB30	PKM30	PKGM30	PKB30	P61230	PXL30
40"	P340	P440	P540	P640	PKMB40	PKM40	PKGM40	PKB40	P61240	PXL40
51"	P351	P451	P551	P651	PKMB51	PKM51	PKGM51	PKB51	P61251	PXL51
60"	P360	P460	P560	P660	PKMB60	PKM60	PKGM60	PKB60	P61260	PXL60
72"	P372	P472	P572	P672	PKMB72	PKM72	PKGM72	PKB72	P61272	PXL72

Standard Zinc: ★ ★

Overall length	3/16" O.D. (Union 3002) 10 per tube	1/4" O.D. (Union 3005) 10 per tube	5/16" O.D. (Union 3007) 5 per tube	3/8" O.D. (Union 3018) 5 per tube	Euro & Domestic (Union 3044) 5 per tube	Japanese (Union 3059) 5 per tube	Toyota / GM (Union 3059) 5 per tube	British / U.S. (Union 3047) 5 per tube	Six Millimeter (Union 4238) 5 per tube
8"	K308	K408	K508	K608	KMB8	KM8	KGM8	KB8	61208
12"	K312	K412	K512	K612	KMB12	KM12	KGM12	KB12	61212
20"	K320	K420	K520	K620	KMB20	KM20	KGM20	KB20	61220
30"	K330	K430	K530	K630	KMB30	KM30	KGM30	KB30	61230
40"	K340	K440	K540	K640	KMB40	KM40	KGM40	KB40	61240
51"	K351	K451	K551	K651	KMB51	KM51	KGM51	KB51	61251
60"	K360	K460	K560	K660	KMB60	KM60	KGM60	KB60	61260
72"	K372	K472	K572	K672	KMB72	KM72	KGM72	KB72	61272

Armored Zinc: ★ ★

Overall length	3/16" O.D. (Union 3002) 10 per tube	1/4" O.D. (Union 3005) 10 per tube	5/16" O.D. (Union 3007) 5 per tube	3/8" O.D. (Union 3018) 5 per tube	Euro & Domestic (Union 3044) 5 per tube	Japanese (Union 3059) 5 per tube
8"	K308A	K408A	K508A	K608A	KMB8A	KM8A
12"	K312A	K412A	K512A	K612A	KMB12A	KM12A
20"	K320A	K420A	K520A	K620A	KMB20A	KM20A
30"	K330A	K430A	K530A	K630A	KMB30A	KM30A
40"	K340A	K440A	K540A	K640A	KMB40A	KM40A
51"	K351A	K451A	K551A	K651A	KMB51A	KM51A
60"	K360A	K460A	K560A	K660A	KMB60A	KM60A
72"	K372A	K472A	K572A	K672A	KMB72A	KM72A

Galvanized Wire Spring Armor

Overall length	Part No. 2 per pack
3/16" x 96"	K396
1/4" x 96"	K496
5/16" x 96"	K596
3/8" x 96"	K696



8" Master Cylinder Adapter Lines
Assortment # 0443 - 35 pieces



Part No. 5 per Tube	Tube Size	Thread & Flare Tube Nut ¹	Thread & Flare Tube Nut ²	Hex Size	Nut color
913-001	1/4"	7/16"-24 Invert	7/16"- 24 Invert	9/16"	Gold
913-002	3/16"	3/8"-24 Invert	7/16"- 24 Invert	7/16"	Red
913-003	3/16"	3/8"-24 Invert	1/2"- 20 Invert	1/2"	Black
913-004	3/16"	3/8"-24 Invert	1/2"- 20 Invert	9/16"	Green
913-005	1/4"	7/16"-24 Invert	9/16"- 18 Invert	9/16"	Blue
913-006	3/16"	3/8"-24 Invert	9/16"- 18 Invert	5/8"	Olive
3026416	1/4"	7/16"-24 Invert	1/2"- 20 Invert	1/2"	Gold
3028316	3/16"	3/8"-24 Invert	10mm -1.0 Bubble	11mm	Olive
30283040	3/16"	10mm x 1.0 Bubble	11mm x 1.5 Bubble	12mm	Orange
30283041	3/16"	10mm x 1.0 Bubble	12mm x 1.0 Bubble	14mm	Blue
30283042	3/16"	10mm x 1.0 Bubble	13mm x 1.5 Bubble	14mm	Green
3040316	3/16"	3/8"-24 Invert	11mm x 1.5 Bubble	12mm	Orange
3041316	3/16"	3/8"-24 Invert	12mm x 1.0 Bubble	14mm	Blue
3042316	3/16"	3/8"-24 Invert	13mm x 1.5 Bubble	14mm	Green
3043316	3/16"	3/8"-24 Invert	10mm x 1.0 Invert	10mm	Blue
3413416	1/4"	7/16"-24 Invert	12mm x 1.0 Bubble	13mm	Olive
3447416	1/4"	7/16"-24 Invert	9/16"- 18 Long	5/8"	Silver
3462416	1/4"	7/16"- 24 Invert	9/16"- 18 Bubble	13mm	Gold
60812	6mm	12mm x 1.0 Bubble	12mm x 1.5 Bubble	14mm	Olive
60814	6mm	12mm x 1.0 Bubble	14mm x 1.5 Bubble	16mm	Black

Female Brake Line Splices



Part No. 10 per Tube	Tube	Thread	Part No. 10 per Tube	Tube	Thread
PF308	3/16"	3/8"-24	PF340	3/16"	3/8"-24
PF312	3/16"	3/8"-24	PF351	3/16"	3/8"-24
PF320	3/16"	3/8"-24	PF360	3/16"	3/8"-24
PF330	3/16"	3/8"-24	PF372	3/16"	3/8"-24

Master Cylinder and A.B.S. Repair Lines



Part No.	Tube Size
51274HP	6mm x 12mm - 1.0 x 22"- Bubble Flare
51275HP	3/16" - 3/8" x 24 TPI x 22"- Inverted Flare
51276HP	1/4" - 7/16" x 24 TPI x 22"- Inverted Flare
51277HP	3/16" - 10mm - 1.0 x 22"- Inverted Flare
51278HP	3/16" - 10mm x 1.0 x 22"- Bubble Flare

Hose Inlet Flex Line Gaskets
Assortment # 0231 - 48 pieces

Part No. 10 Per pack	Outside Diameter	Inside Diameter	Thickness
3046	.625"	.450"	.079"
3048	.687	.450"	.038"
3052	.8125"	.500"	.032"
3053	.625"	.390"	.063"
3054	.8125	.438"	.063"
3055	.625"	.406"	.101"
3056	.688"	.391"	.050"
3057	.554"	.409"	.032"



Flex Line Retainer Clip
Part # 3011
10 per Pack

Brake and Fuel Tubing Clips for Steel or Nylon
Assortment # 0477 - 38 pieces



Part # 3501 1 slot (1) 1/4"	Part # 3502 5 slot (2) 3/16" - (2) 5/16" - (1) 3/8"	Part # 3503 4 slot (1) 1/4" - (2) 5/16" - (1) 3/8"
Part # 3504 1 slot (1) 3/16"	Part # 3506 2 slot (2) 3/16"	Part # 3507 4 slot (1) 1/4" (2) 5/16" - (1) 3/8"
Part # 3508 4 slot (2) 1/4" - (2) 5/16"		

Hose Inlet Flex Line Bolt
Assortment # 0108 - 21 pieces

Part No. 2 per pack	Application
5155	General Motors - M10 x 1.5 x 32.65mm
21079	Chrysler - 7/16" - 20 x 1.345"
21081	Chrysler - M11 x 1.25 x 1.184"
21082	General Motors - 7/16" - 20 x 1.275"
21707	Ford - M10 x 1.0 x 1.15"
22453	Ford - 3/8" - 24 x 1.26"
H9469-2	Ford - 10mm x 1.5 x 1.32
H9449-2	GM - 10mm x 1.5 x 30.58mm
H9470-2	Ford - 10mm x 1.5 x 1.43



Bleeder Screws and Rubber Caps Assortment # 0475 - 144 pieces



Part No.	Thread & Length	Part No.	Thread & Length	Part No.	Thread & Length	Part No.	Thread & Length	Part No.	Thread & Length	Part No.	Thread & Length	Part No.	Thread & Length				
9400	3/8"-3/8"-24 Length-1.36"	9402	3/8"-3/8"-24 Length-1.11"	9403	5/16"-5/16"-24 Length-1.11"	9404	1/4"-3/8"-24 Length-1.36"	9405	M8-M8-1.25 Length-23.5mm	9406	M10-M10-1.5 Length-27.5mm	9407	M10-M10-1.0 Length-27.5mm	9409	M10-M10-1.0 Length-32.75mm		
9410	M10-M10-1.0 Length-35mm	9411	M7-M7-1.0 Length-32mm	9412	M10-M10-1.0 Length-38.5mm	9413	M7-M7-1.0 Length-38.55mm	9415	7/16"-7/16"-20 Length-1.27"	9416	M8-M8-1.0 Length-38mm	9417	1/4"-1/4"- 28 Length-1.045"	9421	M10-M10-1.25 Length-33mm	9422	M8-M8-1.25 Length-32.7mm
9427	7/16"-7/16"-24 Length-1.475mm	9428	M8-M8-1.25 Length-36mm	9430	M8-M8-1.0 Length-26.29mm	9444	Broken Bleeder Repair Fitting	9450	Rubber Cap	9451	Rubber Cap						

Standard Packaging of 10 pieces

Standard Steel Tube Nut Invert Flare

Part #	Tube Size	Thread Diameter	Threads Per Inch
3000	3/16"	3/8"	24 T.P.I
3003	1/4"	7/16"	24 T.P.I
3006	5/16"	1/2"	20 T.P.I
3015	3/8"	5/8"	18 T.P.I
3016	1/2"	3/4"	18 T.P.I
3399 (4pk)	7/16"	11/16"	18 T.P.I
3415	1/4"	7/16" 9/16" HEX	24 T.P.I
3424	3/16"	3/8" 7/16" HEX	24 T.P.I
3441	3/16"	3/8" 9/16" HEX	24 T.P.I

Long Steel Tube Nuts

Part #	Tube Size	Thread Diameter	Thread Pitch
3001	3/16"	3/8"	24 T.P.I
3004	1/4"	7/16"	24 T.P.I
3442	3/8"	5/8"	18 T.P.I

(2 per pack)

Stainless Steel Tube Nuts

Part #	Tube Size	Thread Diameter	Thread Pitch
3000SS	3/16"	3/8"	24 T.P.I
3003SS	1/4"	7/16"	24 T.P.I
3001SS	3/16"	3/8"	24 T.P.I
3004SS	1/4"	7/16"	24 T.P.I

NEW

Metric & Imperial Bubble Flare Tube Nuts



Part #	Tube Size	Thread Diameter	Thread Pitch
3028	3/16"	10mm	1.0 European and Domestic (Olive)
3040	3/16"	11mm	1.5 Domestic (Orange/ Grey)
3041	3/16"	12mm	1.0 Domestic (Blue)
3042	3/16"	13mm	1.5 Domestic (Green)
3410	3/16"	3/8"	24 T.P.I US British Thread (Red)
3411	3/16"	10mm	1.0 Long Tube Nut (Yellow)
3413	1/4"	12mm	1.0 Ford and Imports (Olive)
3414	3/16"	10mm	1.0 Volkswagen and Audi (Violet)
3420	3/16"	10mm	1.0 Ford (Gold)
3426	3/16"	12mm	1.25 (Olive)
3433	1/4"	12mm	1.25 (Gold)
3447	1/4"	12mm	1.75 (Yellow)
3461	1/4"	12mm	1.25 (Black)
3463	3/16"	10mm	1.0 (Grey)
3470	3/16"	10mm	1.25 (Silver)
3477	3/16"	11mm	1.0 (Red)
3490	1/4"	11mm	1.0 (Red)
3492	3/16"	10mm	1.5 (Violet)
3493	3/16"	12mm	1.0 Long (Green)
3495	1/4"	12mm	1.5 (Gold)
3496	1/4"	12mm	1.0 Short Dog Point (Gold)

NEW

Metric Invert Flare Tube Nuts



Part #	Tube Size	Thread Diameter	Thread Pitch
3043	3/16"	10mm	1.0 Japanese (Blue)
3411	3/16"	10mm	1.0 Japanese (Gold) 12mm Hex Long
3413	1/4"	12mm	1.0 Ford and Imports (Black)
3417	3/16"	10mm	1.0 Toyota and GM (Blue) Long
3449	3/16"	10mm	1.0 (Yellow)
3495	1/4"	12mm	1.5 (Gold)
3496	1/4"	12mm	1.0 Short Dog Point (Gold)

Oversize Steel Tube Nuts



Part #	Tube Size	Thread Diameter	Thread Pitch
3022	3/16"	7/16"	24 T.P.I (Red)
3023	3/16"	1/2"	20 T.P.I (Green)
3024	3/16"	9/16"	18 T.P.I (Olive/Gold)
3025	1/4"	9/16"	18 T.P.I (Blue)
3026	1/4"	1/2"	20 T.P.I (Gold)
3439	3/16"	1/2"	20 T.P.I (Black)
3462	1/4"	9/16"	18 Bubble Flare (Yellow)
3494	3/16"	1/2"	20 T.P.I Long (Black)

Metric 6mm Tubing Bubble Flare Tube Nuts



Part #	Tube Size	Thread Diameter	Thread Pitch
3421	6mm	12mm	1.0 (Olive)
3422	6mm	12mm	1.5 (Olive)
3423	6mm	14mm	1.5 (Black)

Brake Line Union Tees

(2 per pack)

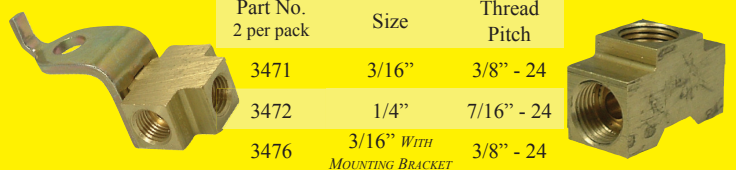

Part No.	Size	Thread Pitch
3471	3/16"	3/8" - 24
3472	1/4"	7/16" - 24
3476	3/16" WITH MOUNTING BRACKET	3/8" - 24

BRAKE LINE TUBE NUTS

CARLSON

CARLSON QUALITY BRAKE HARDWARE QUALITY BRAKE PARTS FOR CARS & TRUCKS

Over 3000
Sku's!

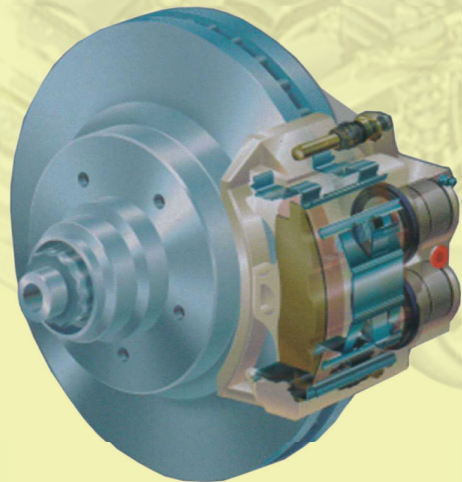

- Domestic/Import
- Disc Brake Hardware
- Drum Brake Hardware
- Disc Pad Installation Kits
- Parking Brake Kits
- Caliper Hydraulic Kits
- Brake Line Fittings

FMSI Automotive hardware Carries the Complete Carlson Brake Hardware program ask for your catalogue on your next order

CARLSON QUALITY BRAKE

Master Cylinder Adapter Invert Flare



Invert Male

Part # 10 per pack	Tube Size (Female)	Female Thread	Tube Size (Male)	Male Thread
3230	3/16"	3/8" x 24	5/16"	1/2" - 20
3231	3/16"	3/8" x 24	3/8"	9/16" - 20
3232	3/16"	3/8" x 24	1/4"	7/16" - 24
3233	1/4"	7/16" x 24	5/16"	1/2" - 20
3235	1/4"	7/16" x 24	3/16"	3/8" - 24
3236	1/4"	7/16" x 24	3/8"	9/16" - 18
3237	3/16"	3/8" x 24	3/8"	9/16" - 18
3418 (2 pk)	5/16"	1/2" x 20	3/8"	5/8" - 18
3419 (1 pk)	3/8"	5/8" x 18	5/16"	1/2" - 20
NEW 4603	5/16"	1/2" x 20	1/4"	7/16" - 24
NEW 4601	3/16"	1/2" x 20	3/16"	9/16" - 18
NEW 4602	3/16"	9/16" x 18	3/16"	1/2" - 20

Master Cylinder Adapter Invert Flare

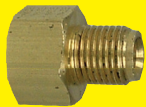

Surface Seal Male

Part # 10 per pack	Tube Size (Female)	Female Thread	Tube Size (Male)	Male Thread
3029	1/4"	7/16" x 24	1/4"	7/16" - 20
3233	1/4"	7/16" x 24	5/16"	1/2" - 20
NEW 4609	3/16"	3/8" x 24	3/16"	1/2" - 20
NEW 4611	5/16"	1/2" x 20	5/16"	1/2" - 20

Invert Flare



Bubble Flare Male

Part # 2 per pack	Tube Size (Female)	Female Thread	Tube Size (Male)	Male Thread
3255	3/16"	3/8" x 24	3/16"	3/8" - 24
3478	3/16"	3/8" x 24	3/16"	1/2" - 18
NEW 4607	3/16"	3/8" x 24	1/4"	7/16" - 20

Invert Flare



Pipe Thread Male

Part No. 5 per pack	Tube Size	Pipe Thread
3481	3/16"	1/8"
3482	1/4"	1/8"
3483	1/4"	1/4"
3484	5/16"	1/8"
3485	5/16"	1/4"
3486	3/8"	1/4"

3/16" Invert Flare



Metric Bubble Flare

Part # 10 per pack	Tube Size (Female)	Female Thread	Tube Size (Male)	Male Thread
3039	3/16"	3/8" x 24	3/16"	10mm x 1.0
3250	3/16"	3/8" x 24	3/16"	10mm x 1.25
3251	3/16"	3/8" x 24	3/16"	13mm x 1.5
3252	3/16"	3/8" x 24	3/16"	12mm x 1.0
3253	3/16"	3/8" x 24	3/16"	11mm x 1.5
NEW 4612	3/16"	3/8" x 24	3/16"	11mm x 1.25
NEW 4613	3/16"	3/8" x 24	3/16"	12mm x 1.25
NEW 4616	3/16"	3/8" x 24	3/16"	11mm x 1.0
NEW 4619	3/16"	3/8" x 24	3/16"	10mm x 1.5

1/4" Invert Flare



Metric Bubble Male

Part # 10 per pack	Tube Size (Female)	Female Thread	Tube Size (Male)	Male Thread
4614	1/4"	7/16" x 24	1/4"	12mm x 1.25
4615	1/4"	7/16" x 24	1/4"	12mm x 1.75
4650	1/4"	7/16" x 24	1/4"	12mm x 1.5
4617	1/4"	7/16" x 24	1/4"	11mm x 1.0
4618	1/4"	7/16" x 24	1/4"	14mm x 1.5

Metric Bubble Flare



Metric Bubble Male

Part # 10 per pack	Tube Size (Female)	Female Thread	Tube Size (Male)	Male Thread
3254	3/16"	10mm x 1.25	3/16"	13mm x 1.5
NEW 4606	3/16"	10mm x 1.0	3/16"	13mm x 1.5
NEW 4604	3/16"	10mm x 1.0	3/16"	11mm x 1.5
NEW 4605	3/16"	10mm x 1.0	3/16"	12mm x 1.0

3/16" Invert Flare



Metric Invert Male

Part # 10 per pack	Tube Size (Female)	Female Thread	Tube Size (Male)	Male Thread
3045	3/16"	3/8" x 24	3/16"	10mm x 1.0
3479	3/16"	3/8" x 24	3/16"	10mm x 1.25

Metric Invert Flare



Metric Bubble Male

Part # 2 per pack	Tube Size (Female)	Female Thread	Tube Size (Male)	Male Thread
3473	3/16"	10mm x 1.0	3/16"	11mm x 1.5
3474	3/16"	10mm x 1.0	3/16"	12mm x 1.0
3475	3/16"	10mm x 1.0	3/16"	13mm x 1.5

HEAVY WALL BRASS BRAKE LINE UNIONS

Brake Line Union Standard Flare

Part No. 10 per pack	Tube Size	Thread Diameter	Threads Per Inch
3002	3/16"	3/8"	24 T.P.I
3005	1/4"	7/16"	24 T.P.I
3007	5/16"	1/2"	20 T.P.I
3018	3/8"	5/8"	18 T.P.I
3020	3/16"-1/4"	3/8"-7/16"	24 T.P.I

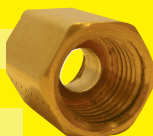

Brake Line Union Bubble Flare Metric & Standard

Part No. 10 per pack	Tube Size	Thread Diameter	Threads Per Inch
3044	3/16"	10mm	1.0 Bubble Flare <i>Dom / Euro</i>
3047	3/16"	3/8"	24 T.P.I Bubble Flare <i>British</i>
4238	6mm, 3/16", 1/4"	12mm	1.0 Bubble Flare <i>Japanese</i>



Brake Line Union Japanese Invert Flare

Part No. 10 per pack	Tube Size	Thread Diameter	Threads Per Inch
3059	3/16"	10MM	1.0 Invert Flare <i>Japanese</i>



BRASS BRAKE LINE ADAPTERS 9

Parts Store Brass Assortment # 0130

Brass Pipe Elbow



Part No. 1 Per pack	Size	Edelmann	Weatherhead
3510	1/8"	200200	3500X2
3511	1/4"	200400	3500X4
3512	3/8"	200600	3500X6

NEW

Brass Pipe Tee



Part No. 1 Per pack	Size	Edelmann	Weatherhead
3513	1/8"	201200	3700X2
3514	1/4"	201400	3700X4
3515	3/8"	201600	3700X6

NEW

Brass Pipe Coupling

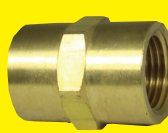

Part No. 1 Per pack	Size	Edelmann	Weatherhead
3560	1/8"	203200	3300X2
3561	1/4"	203400	3300X4
3562	3/8"	203600	3300X6
3563	1/2"	n/a	n/a

NEW

Brass Pipe Street Tee

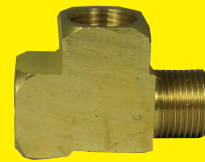

Part No. 1 Per pack	Size	Edelmann	Weatherhead
3519	1/8"	227200	3750X2
3520	1/4"	227400	3750X4
3522	3/8"	227600	3750X6

NEW

Brass Pipe End Cap



Part No. 1 Per pack	Size	Edelmann	Weatherhead
3523	1/8"	208200	3129X2
3524	1/4"	208400	3129X4
3525	3/8"	208600	3129X6

NEW

Brass Pipe Square Head Plug



Part No. 1 Per pack	Size	Edelmann	Weatherhead
3526	1/8"	221200	3151X2
3527	1/4"	221400	3151X4
3528	3/8"	221600	3151X6

NEW

Brass Pipe to Pipe Bushing



Part No. 1 Per pack	Size	Edelmann	Weatherhead
3529	1/4"-1/8"	210420	3220X4X2
3530	3/8"-1/8"	210620	3220X6X2
3531	3/8"-1/4"	210640	3220X6X4

NEW

Brass Pipe to Pipe Bushing



Part No. 1 Per pack	Size	Edelmann	Weatherhead
3532	1/2"-1/8"	210820	3220X8X2
3533	1/2"-1/4"	210840	3220X8X4
3534	1/2"-3/8"	210860	3220X8X6

NEW

Brass Pipe Closed Nipple



Part No. 1 Per pack	Size & (Length)	Edelmann	Weatherhead
3535	1/8" (3/4")	212200	3326X2
3536	1/4" (7/8")	212400	3326X4
3537	3/8" (1")	212600	3326X6

NEW

Brass Pipe Long Nipple



Part No. 1 Per pack	Size & (Length)	Edelmann	Weatherhead
3538	1/8" (1-1/2")	213210	3327X2
3539	1/8" (2")	213220	3328X2
3540	1/4" (1-1/2")	213410	3327X4
3541	1/4" (2")	213420	3328X4
3542	3/8" (1-1/2")	213610	3327X6

NEW

Brass Pipe Street Elbow

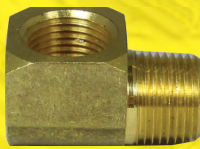

Part No. 1 Per pack	Size	Edelmann	Weatherhead
3543	1/8"-1/8"	216200	3328X6
3544	1/4"-1/4"	216400	3400X4
3545	3/8"-3/8"	216600	3400X6

NEW

Brass Internal Slot Pipe Plug



Part No. 1 Per pack	Size	Edelmann	Weatherhead
3546	3/8"	217600	3150X2

NEW

Brass Internal Hex Head Pipe Plug

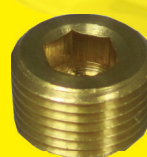

Part No. 1 Per pack	Size	Edelmann	Weatherhead
3547	1/8"	226200	n/a
3548	1/4"	226400	n/a
3549	3/8"	226600	n/a

NEW

45° Brass Pipe Elbow



Part No. 1 Per pack	Size	Edelmann	Weatherhead
3575	1/8"	224200	3350X2
3576	1/4"	224400	3350X4
3577	3/8"	224600	3350X6

NEW

Brass External Hex Head Pipe Plug

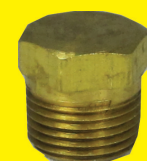

Part No. 1 Per pack	Size	Edelmann	Weatherhead
3551	1/8"	n/a	n/a
3554	1/2"	n/a	n/a

NEW

Brass Pipe Reducer Couplers



Part No. 1 Per pack	Size	Edelmann	Weatherhead
3555	1/4"-1/8"	219420	3300X4X2
3556	3/8"-1/4"	219640	3300X6X4

NEW

Brass Pipe to Pipe Adapter

NEW

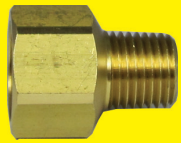

Part No. 1 Per pack	Size (F) - (M)	Edelmann	Weatherhead
3557	1/8"-1/8"	220220	3200X2
3558	1/4"-1/8"	220420	3200X4X2
3559	1/4"-1/4"	220440	3200X4
3564	3/8"-1/4"	220640	3200X6X4
3565	3/8"-3/8"	220600	3200X6

Brass Pipe to Pipe Hex Nipple

NEW

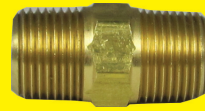

Part No. 1 Per pack	Size	Edelmann	Weatherhead
3568	1/8"-1/8"	222220	3325X2
3569	1/4"-1/4"	222440	3325X4
3572	1/4"-1/8"	222420	3325X4X2
3573	3/8"-3/8"	222660	3325X6
3574	3/8"-1/4"	222640	3325X6X4

Brass Hex Head Plug

NEW



Part No. 1 Per pack	Size	Edelmann	Weatherhead
3552	1/4"	209400	3152X4
3553	3/8"	209600	3152X6

Brass Drain Cock

NEW



Part No. 1 Per pack	Size	Edelmann	Weatherhead
3578	1/8"	310200	135
3579	1/4"	311400	145
3580	3/8"	312600	270

Brass Hose to Pipe



Part # 2 per pack	Hose I.D.	Pipe Thread
4275	1/4"	1/8"
4276	1/4"	1/4"
4277	3/8"	1/8"
4278	3/8"	1/4"
4279	3/8"	3/8"
4280	1/2"	3/8"
4249	5/8"	3/8"

NEW

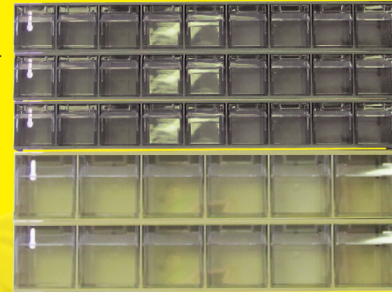

Parts Store Brass Assortment # 0130

COMPRESSION UNIONS BRASS & STEEL



Part No. 2 Per pack	Size Steel to Steel
2952	1/8"
2955	3/16"
2956	1/4"
2957	5/16"
2958	3/8"

Part No. 4 Per pack	Size Steel to Nylon
2941	1/4"
2942	5/16"
2943	3/8"

Part No. 25 Per pack	Brass Ferrule
3209	3/16"
3210	1/4"
3211	5/16"
3212	3/8"

Part No. 2 Per pack	Size Nylon to Nylon
2890	1/4"
2891	5/16"
2892	3/8"

Part No. 25 Per pack	Nylon Ferrule
3206	1/4"
3207	5/16"
3208	3/8"

Part No. 1 Per pack	Size High Pressure (5000psi)
3451	3/16"
3452	1/4"
3453	5/16"
3454	3/8"
3459	10mm

360° SEAL COMPRESSION UNIONS

JOIN STEEL, COPPER, NYLON, ALUMINUM TUBING

360° Seal Inline Captive Sleeve & Standard Compression Union



Part No. 2 Per pack	Size Straight
2855	3/16"
2856	1/4"
2857	5/16"
2858	3/8"
2859	10mm Nylon Only

Part No. 4 Per pack	Size Reducer
2840	5/16" to 1/4"
2841	3/8" to 5/16"
2842	10mm to 3/8" Nylon Only
2843	10mm to 5/16" Nylon Only

Part No. 2 Per pack	Size 90° Elbow
2845	1/4"
2846	5/16"
2847	3/8"
2848	3/8" (10mm)
2849	10mm

Part No. 2 Per pack	Size Captive Sleeve
3213	3/16"
3214	1/4"
3215	5/16"
3216	3/8"

(2 per pack)	Part No. 3241		10mm Inline Sleeve
(2 per pack)	Part No. 3240		10mm Sleeve Nut

Ferrule centered and attached to nut to ensure leak free connection



FOR APPLICATION GUIDE CONTACT US AT:

Tel: 800-651-7445 • Fax: 905-335-1829 • Email: info@fmsiinc.com • <http://www.fmsiinc.com>

FUEL FILLER NECKS

Over 400 Applications

AVAILABLE APPLICATIONS

Acura	Jeep
Buick	Kia
Cadillac	Lexus
Chevrolet	Lincoln
Chrysler	Mazda
Dodge	Mercury
Dodge Trucks	Nissan
Eagle	Nissan Trucks
Ford	Oldsmobile
Ford Trucks	Plymouth
Geo	Pontiac
GMC	Saturn
Honda	Subaru
Hyundai	Suzuki
Infiniti	Toyota
Isuzu	Toyota Trucks

TOYOTA COROLLA
'93 - '97

CHEVY S10 / S15
'98 - '00

CHEVY CAVALIER
'99 - '04

DODGE NEON
'00 - '02

FILLER NECK TO FUEL TANK HOSE



Item # 6498
1-1/2" x 24"

Item # 6499
2" x 24"

NEW

Manufactured to flow fuel from filler neck to fuel tank in automotive and auxiliary tanks, or wherever fuel transfer is required. Meets SAE J30R7 Specifications

360° Seal Clamps

Positive 360° seal with no gaps on the inside of the clamp.
Smooth inner band prevents damage to the tube or hose



360° Seal Clamp Pincers

Part No. 5414

Center Anvil assures perfect seal



Part # 10 per pack	Size	I.D.	Application
2940	7.0mm	9/32"	6mm - 1/4" nylon fuel lines (2997)
2950	8.7mm	11/32"	8mm - 5/16" nylon fuel lines (2962)
2980	9.5mm	3/8"	8mm - 5/16" nylon fuel lines (2962)
2981	10.5mm	13/32"	3/8" nylon fuel line (2998)
2982	11.3mm	7/16"	10mm - 3/8" nylon fuel lines (2998)
2983	12.3mm	15/32"	Fuel, Transmission & Coolant hose
2984	13.3mm	1/2"	Fuel, Transmission & Coolant hose
2985	14.5mm	9/16"	Fuel, Transmission & Coolant hose
2986	15.7mm	7/8"	1/4" shop air line
2987	17.0mm	11/16"	3/8" shop air line
2988	18.5mm	23/32"	3/8" shop air line
3227	19.8mm	25/32"	Fuel, Transmission & Coolant hose
2989	21.0mm	13/16"	Fuel, Transmission & Coolant hose
2990	24.1mm	15/16"	Use with item # 4204 (5/8")
2991	25.6mm	1"	Fuel, Transmission & Coolant hose
2995	28.6mm	1-1/8"	Use with item # 4205 - 4215

Nylon Fuel Line Tubing Joiners



Part No. 2 Per pack	Size Splice
2959	5/16" (8mm)
2968	10mm
2994	1/4" (6mm)
3220	3/8"

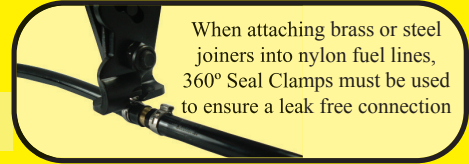

When attaching brass or steel joiners into nylon fuel lines, 360° Seal Clamps must be used to ensure a leak free connection

Nylon Fuel Line Tubing Joiner Tees

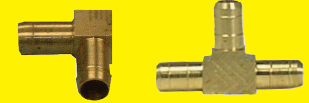

Part No. 2 Per pack	Size Tee's & 90° Elbows
3223	1/4" (Tee)
3224	5/16" (8mm) & 3/8" (Tee)
3225	1/4" (Elbow)
3226	5/16" (Elbow)

Nylon Fuel Line Tubing Reducers

Part No. 2 Per pack	Size
3204	1/4" to 5/16" (8mm)
3205	5/16" (8mm) to 3/8" (10mm)

Nylon Fuel Line Quick connect Joiner



Part No. 2 Per pack	Size Push Quick Connects
2945	1/4"
2946	8mm
2947	3/8"
2948	10mm
2949	5/16"

Quickly repair damaged or degraded original equipment tubing

Convuluted Nylon Fuel Line Tubing

Part #	Tube O.D	Coil Length
2936	5/16" (8mm)	25'
2937	10mm	25'
2936-36	5/16" (8mm)	36"
2937-36	10mm	36"



Cuffs every 3 feet for connectors and joiners to be installed on 25' coils

Convuluted Nylon Repair Lines

Part #	Tube O.D	Length
2962CVT	5/16" (8mm)	10"
2963CVT	10mm	10"

GM Tank Sender Hose Line Fitting

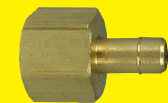

Nylon Tube

Part #	Thread Size	Tube Size
4236	16mm x 1.5	10mm
4237	14mm x 1.5	8mm

Nylon 11 Black Fuel Rated Tubing for replacement of steel or nylon tubing

Part #	Tube O.D	Coil Length
2962 - 25	5/16" (8mm)	25'
2962 - 100	5/16" (8mm)	100'
2962 - 1000	5/16" (8mm)	1000'
2963 - 25	10mm	25'
2963 - 100	10mm	100'
2963 - 1000	10mm	1000'
2997 - 25	1/4"	25'
2997 - 100	1/4"	100'



220-250 P.S.I
WORKING PRESSURE
800-1000 P.S.I
BURST PRESSURE

Part #	Tube O.D	Coil Length
2997 - 1000	1/4"	1000'
2998 - 25	3/8"	25'
2998 - 100	3/8"	100'
2998 - 1000	3/8"	1000'
3350 - 10	1/2"	10'
3350- 25	1/2"	25'
3351-10	5/8"	10'
3351-25	5/8"	25'

High Pressure Fuel Injection Hose



Part #	Hose I.D	Coil Length
FIL 1	1/4"	10'
FIL1A	1/4"	25'
FIL1B	1/4"	250'
FIL2	5/16"	10'
FIL2A	5/16"	25'
FIL2B	5/16"	250'
FIL3	3/8"	10'
FIL3A	3/8"	25'
FIL3B	3/8"	250'

Fuel Injection Hose Clamps

FI4	1/4"	Fuel injection hose clamp
FI6	5/16"	Fuel injection hose clamp
FI8	3/8"	Fuel injection hose clamp
FI10	10mm - 12mm	Fuel injection hose clamp



GM TANK SENDER REPLACEMENT HOSE LINES



GM Truck Tank Sender Unit
Hose Extension Repair Line.

Part #	Description	Style
4352	5/16" x 10" - Tank hose 14mm x 1.5 female ends	1
4353	5/16" x 16" - Tank hose 14mm x 1.5 female ends	1
4356	3/8" x 32" - 8" crimped hose section - 24" steel section	4
4357	5/16" x 32" - 8" crimped hose section - 24" steel section	4
4358	3/8" x 10" - Tank hose 16mm x 1.5 female ends	1
4359	3/8" x 16" - Tank hose 16mm x 1.5 female ends	1
4354	3/8" x 12" w/ 180° male tube end 16mm x 1.5 female 16mm x 1.5	3
4350	3/8" x 10" - male steel tube w/ 16mm x 1.5 to female 16mm x 1.5	2
4351	3/8" x 16" - male steel tube w/ 16mm x 1.5 to female 16mm x 1.5	2

Steel Quick Connector to Fuel Injection Hose



Part #	Size	Description
3093	5/16"	Chrysler & GM sending unit / filter (Straight)
3094	5/16"	Chrysler & GM sending unit / filter (Angled)

Brass Hose Joiners

Part No.	Size
2 Per pack	Barbed Mender
2885	1/4"
2886	5/16"
2887	3/8"
2894	1/2"
2895	5/8"
2896	3/4"
2898	12mm
2899	5/8"

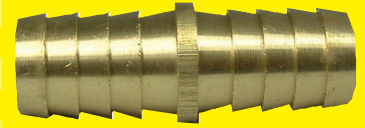

GM Tank Sender Hose Line Fitting

Part #	Size
4300	16mm x 1.5
4301	14mm x 1.5

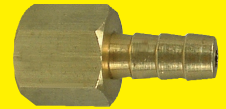

GM Hi Flow Union

Hi Flow

Part #	Size
4302	16mm x 1.5
4303	14mm x 1.5



Brass Female Tube Nuts

Part #	Tube Size	Thread Diameter	Thread Pitch
3428 (Brass)	3/16"	3/8"	24 T.P.I
3429 (Brass)	1/4"	7/16"	20 T.P.I
3430 (Brass)	5/16"	1/2"	20 T.P.I
3431 (Brass)	3/8"	5/8"	18 T.P.I
3432 (Brass)	1/2"	3/4"	18 T.P.I
3489 (Steel)	5/16"	1/2"	20 T.P. I



FUEL LINE TUBE NUTS



Part #	Tube Size	Thread Diameter	Thread Pitch
3008	3/8"	16mm	1.5 GM (Olive)
3009	5/16"	14mm	1.5 GM (Olive)
3445	5/16"	14mm	1.5 GM Japanese (Yellow)
3448	5/16"	14mm	1.25 Japanese (Silver)
3487	5/16" Coated	14mm	1.5 Toyota (Gold)
3488	5/16" Coated	14mm	1.5 Honda (Olive)

GM Fuel Filter with Pressure Test Port Valve.



Part # 4260

Replaces:
Service Champ - 52073
Fram - G7315
WIX - 33311
Purulator - F54714
AC Delco - GF578

Part # 4261

Replaces:
Service Champ - 52066
Fram - G3727
WIX - 33481
Purulator - F33144
AC Delco - GF481



Domestic Steel Fuel Repair Lines



Part No. 1 Per Pack	Size	Fittings <i>"R" Represents With Attaching Hardware.</i>
3145	3/8" x 4"	16mm GM fitting
3146	5/16" x 4"	14mm GM fitting
3180	3/8" x 6"	16mm GM fitting
3181	5/16" x 6"	14mm GM fitting
3062	3/8" x 9"	16mm GM fitting
3062R		
3063	5/16" x 9"	14mm GM fitting
3063R		
3060	3/8" x 18"	16mm GM fitting
3060R		
3061	5/16" x 18"	14mm GM fitting
3061R		
3064	3/8" x 36"	16mm GM fitting
3064R		
3065	5/16" x 36"	14mm GM fitting
3065R		
3270	3/8" x 60"	16mm GM fitting
3271	5/16" x 60"	14mm GM fitting



Part No. 1 Per Pack	Size	Fittings
3149	3/8" x 6 1/2"	16mm GM / 180° Bend



Part No. 1 Per Pack	Size	Fittings
3066	3/8" x 18"	Male end for quick connect
3067	5/16" x 18"	Male end for quick connect
3095	1/4" x 18"	Male end for quick connect
3293	1/4" x 4"	Male end for quick connect
3294	5/16" x 4"	Male end for quick connect
3295	3/8" x 4"	Male end for quick connect



Part No. 1 Per Pack	Size	Fittings
3188	5/16" x 3 3/4"	Quick Connect to hose end
3189	3/8" x 3 3/4"	Quick Connect to hose end

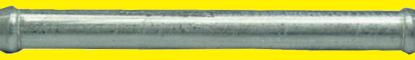

Part No. 1 Per Pack	Size	Fittings
3147	3/8" x 4"	Hose Bump
3148	5/16" x 4"	Hose Bump
3771	3/8" x 24"	Hose Bump

Import Steel Fuel Repair Lines



Part No. 1 Per Pack	Size	Fittings
3487K	5/16" x 8 3/4"	14mm Toyota
3488K	5/16" x 8 3/4"	14mm Honda



Part No. 1 Per Pack	Size	Fittings
3445K	5/16" x 12"	Japanese/GM 14mm x 1.5
3448K	5/16" x 12"	Japanese/GM 14mm x 1.25

Steel to Nylon Adapter Lines

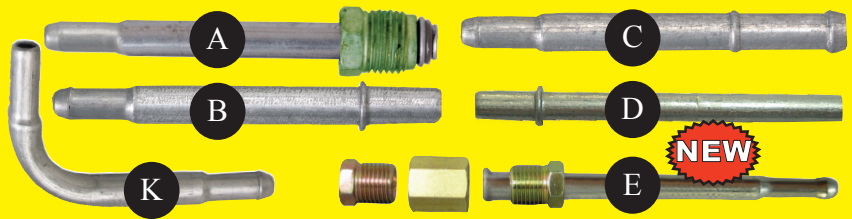

Part #	Size	Application	Type
3116	5/16" x 3 3/4" 90° bend repair elbow.	(connects to 5/16" (8mm) nylon tube 2962)	K
3117	3/8" x 3 3/4"	For Quick connector Ford/GM/Chrysler. (use with 3/8" nylon tube 2998)	B
3118	5/16" x 3 3/4"	For Quick connector Ford/GM/Chrysler.(use with 5/16" (8mm) nylon tube 2962)	B
3119	5/16" x 3 3/4"	14mm fitting GM. (use with 5/16" nylon tube 2962)	A
3120	3/8" x 3 3/4"	16mm fitting GM. (use with 3/8" nylon tube 2998)	A
3121	3/8" x 3 3/4"	Hose end Ford/GM/Chrysler. (use with 3/8" nylon tube 2998)	C
3122	5/16" x 3 3/4"	Hose end Ford/GM/Chrysler. (use with 5/16"(8mm) nylon tube 2962)	C
3133	3/8" x 3 3/4"	Hose end Ford/GM/Chrysler. (use with 10mm nylon tube 2963)	C
3134	3/8" x 3 3/4"	For Quick connector Ford/GM/Chrysler. (use with 10mm nylon tube 2963)	B
3135	3/8" x 3 3/4"	16mm fitting GM.(use with 10mm nylon tube 2963)	A
3136	3/8" x 3 3/4"	For 90° bends and sending unit repairs. (connects to 5/16"(8mm) nylon tube 2962)	K
3137	5/16" x 3 3/4"	For 90° bends and sending unit repairs. (connects to 5/16"(8mm) nylon tube 2962)	K
3138	1/4" x 3 3/4"	For Quick connector Ford/GM/Chrysler. (connects to 5/16" (8mm) nylon tube 2962)	D
3143	1/4" x 3 3/4"	For 90° bends and sending unit repairs. (connects to 1/4" nylon tube 2997)	K
3144	1/4" x 3 3/4"	For Quick connector Ford/GM/Chrysler.(connects to 1/4" nylon tube 2997)	B
3162	3/8" x 3 3/4"	90° bend repair elbow. (connects to 10mm nylon tube 2963)	K
3296	5/16" x 4 3/4" 5/16" Tube 1/2"-20	(connects to 5/16" (8mm) nylon tube 2962) Attaching Hardware included	E
3299	3/8" x 4 3/4" 3/8" Tube 5/8"-18	(connects to 10mm nylon tube 2963) Attaching Hardware included	E

SENDING UNIT REPAIR LINES



Part No. 1 Per Pack	Size	Fittings
3075	5/16" x 4 3/4"	GM 14mm Fitting
3161	5/16" x 8 1/2"	GM 14mm Fitting
3077	5/16" x 12"	GM 14mm Fitting
3126	5/16" x 30"	GM 14mm Fitting
3128	5/16" x 36"	GM 14mm Fitting
3074	3/8" x 4 3/4"	GM 16mm Fitting
3160	3/8" x 8 1/2"	GM 16mm Fitting
3076	3/8" x 12"	GM 16mm Fitting
3078	3/8" x 18"	GM 16mm Fitting
3127	3/8" x 30"	GM 16mm Fitting
3129	3/8" x 36"	GM 16mm Fitting



Part No. 1 Per Pack	Size	Fittings
3139	1/4" x 3 3/4"	For quick connect
3073	5/16" x 4"	For quick connect
3073L	5/16" x 4 3/4"	For quick connect
3079	5/16" x 12"	For quick connect
3123	5/16" x 16"	For quick connect
3130	5/16" x 36"	For quick connect
3072	3/8" x 4"	For quick connect
3072L	3/8" x 4 3/4"	For quick connect
3080	3/8" x 12"	For quick connect
3124	3/8" x 16"	For quick connect
3131	3/8" x 36"	For quick connect



Part No. 1 Per Pack	Size	Fittings
3292	1/4" x 4"	For hose end
3291	5/16" x 4"	For hose end
3081	5/16" x 12"	For hose end
3125	5/16" x 16"	For hose end
3083	5/16" x 18"	For hose end

Part No. 1 Per Pack	Size	Fittings
3290	3/8" x 4"	For hose end
3082	3/8" x 12"	For hose end
3084	3/8" x 18"	For Hose end
3132	5/16" x 36"	For hose end

STEEL FUEL REPAIR LINES

NYLON FUEL REPAIR LINES

NYLON FUEL REPAIR LINE

Nylon Fuel Repair Lines

EASILY BENDS 360° TO MAKE THE MOST DIFFICULT OF CONNECTIONS

Part #	Description	Style
3068K	5/16" connector 90° elbow to 8mm / 5/16" nylon Ford, GM	D
3069K	5/16" connector to 8mm / 5/16" nylon Ford	A
3070K	3/8" connector to 8mm / 5/16" nylon Ford	A
3071K	3/8" connector to 10mm nylon Ford	A
3085K	8mm - 5/16" nylon fuel line splice	B
3086K	10mm - 3/8" nylon fuel line splice Universal 12	B
3088K	1/4" connector to 8mm / 5/16" nylon Ford	A
3091K	3/8" connector elbow to 8mm / 5/16" nylon Ford, GM	D
3092K	3/8" connector elbow to 10mm nylon Ford, GM	D
3100K	3/8" connector to 10mm nylon GM	E
3101K	5/16" connector to 8mm / 5/16" nylon GM	E
3153K	5/16" connector elbow to 8mm / 5/16" nylon GM, Chrysler	C
3154K	3/8" connector elbow to 10mm nylon GM, Chrysler	C
3155K	5/16" connector elbow to 10mm nylon GM, Chrysler	C
3156K	5/16" 45° connector elbow to 5/16" (8mm) nylon splice	F
3157K	3/8" 45° connector elbow to 3/8" nylon splice	F
3167	1/4" connector to 8mm / 5/16" nylon GM, Chrysler	E
3169	5/16" connector to 10mm nylon Ford	A



Nylon Quick Connect Fuel Repair Lines

- Repairs nylon sections of fuel system components.
- Easily attaches to existing O.E.M nylon fuel line.
- Completely assembled and ready for installation.
- Splice for repairing leaks anywhere in the fuel line.
- 360° seal clamps included to insure 100% leak free seal.
- Flexible tubing to make bends and turns without kinking.

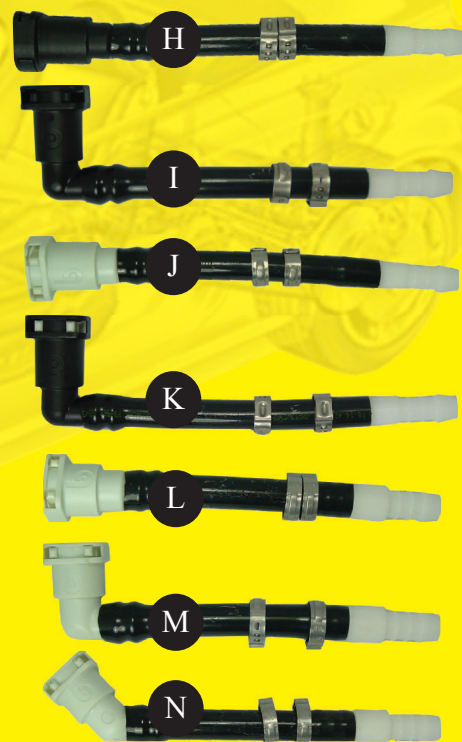

Nylon Evap Repair Lines

Part #	Description	Style
3310K	12mm to 1/2" Evaporator Tube Repair	H
3311K	12mm to 90° Elbow 1/2" Evaporator Tube Repair	I
3312K	1/2" to 1/2" Evaporator Tube Repair	J
3313K	1/2" to 90° Elbow 1/2" Evaporator Tube Repair	K
3314K	5/8" to 5/8" Evaporator Tube Repair	L
3315K	5/8" to 90° Elbow 5/8" Evaporator Tube Repair	M
3316K	5/8" to 45° Elbow 5/8" Evaporator Tube Repair	N

Steel Quick Connector to Nylon Repair Lines

Part #	Size
3164	3/8"
3165	5/16"
3166	1/4"



3163

'95 - early '98 plastic modular fuel sender to filter repair line Cavalier, Sunfire, Grand Am, etc.

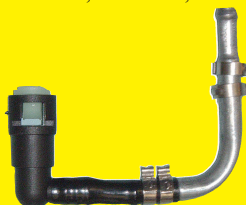

3175

'98 - '02 Plastic modular fuel sender to filter repair line Cavalier, Sunfire.



3176

'98 - up plastic modular fuel sender to filter repair line Grand Am Alero.



0454M MASTER FUEL LINE REPAIR & REPLACE ASSORTMENT WITH INSTALLATION TOOL

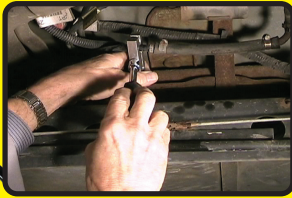

FOR USE ON THE CAR OR BENCH!

3 TIMES FASTER THAN ANY COMPETITORS IMITATION

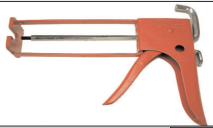

Complete Fuel Line Repair & Replacement Assortment 0454M

<p>3118 3/16" x 3/16" Bar-quick connector GM / Ford / Chrysler & imports for 8mm / 5/16" tubing</p> <p>3119 3/16" x 3/16" Bar-quick connector GM / Ford / Chrysler & imports for 10mm tubing</p> <p>3120 3/16" x 3/16" Male end fitting for 8mm / 5/16" tubing</p> <p>3121 3/16" x 3/16" Male end fitting for 8mm / 5/16" tubing</p> <p>3207 Nylon Connector Nylon Connector Holder</p> <p>3208 Nylon Connector Nylon Connector Holder</p>	<p>3001 Press Tool</p> 	<p>49500 Installation Lubricant</p> <p>49500</p>
--	---	--

Side One
Box - 1 of 2

Complete Fuel Line Repair & Replacement Assortment 0454

<p>2964 5/16" - 90° elbow to 8mm nylon fuel line</p> <p>2965 5/16" - Straight to 8mm nylon fuel line</p> <p>2966 3/8" - Straight to 8mm nylon fuel line</p> <p>2967 3/8" - Straight to 10mm nylon fuel line</p> <p>2971 3/8" - 90° elbow to 10mm nylon fuel line</p> <p>2972 3/8" - 90° elbow to 8mm nylon fuel line</p>	<p>2968 1/4" - Straight to 8mm 5/16" nylon fuel line</p> <p>2973 1/4" - Straight to 8mm 5/16" nylon fuel line</p> <p>2978 3/8" - Straight to 10mm nylon fuel line</p> <p>2979 5/16" - Straight to 8mm 5/16" nylon fuel line</p> <p>3153C 5/16" - 90° elbow to 8mm 5/16" nylon fuel line</p> <p>3154C 3/8" - 90° elbow to 10mm nylon fuel line</p>	<p>3155C 5/16" - 90° elbow to 10mm nylon fuel line</p> <p>3156C 3/8" - 45° Elbow to 10mm nylon fuel line</p> <p>3157C 5/16" - 45° Elbow to 5/16" nylon fuel line</p> <p>3210 12mm Straight to 1/2" tubing</p> <p>3211 12mm 90° elbow to 1/2" tubing</p> <p>3212 1/2" Straight to 1/2" tubing</p>
--	---	--

Side Two
Box - 1 of 2

360° Seal Brass Fitting Assortment (Box # 2) 0454

<p>2980 360° Seal brass cap nut 5/16" - 8mm nylon tubing</p> <p>2981 360° Seal brass cap nut 5/16" - 10mm nylon tubing</p> <p>2982 360° Seal brass cap nut 5/16" - 12mm nylon tubing</p>	<p>2983 360° Seal brass cap nut 5/16" - 8mm nylon tubing</p> <p>2984 360° Seal brass cap nut 5/16" - 10mm nylon tubing</p> <p>2985 360° Seal brass cap nut 5/16" - 12mm nylon tubing</p>	<p>2986 360° Seal brass cap nut 5/16" - 8mm nylon tubing</p> <p>2987 360° Seal brass cap nut 5/16" - 10mm nylon tubing</p> <p>2988 360° Seal brass cap nut 5/16" - 12mm nylon tubing</p>	<p>4236 GM Female Fitting 10mm x 1.5 return line</p> <p>4237 GM Female Fitting 10mm x 1.5 return line</p>
---	---	---	---



Master Fuel Line Repair Assortment # 0454M
90 pieces (2 boxes)

ORIGINAL EQUIPMENT STYLE QUICK CONNECTORS

STOP

FUEL LINE QUICK CONNECTORS ARE A PRESS FIT. CLAMPS NOT REQUIRED.

STICK WITH THE OE.. THEY DO IT THIS WAY FOR A REASON!



<p>2966 3/8" to 8mm / 5/16" nylon fuel line</p> 	<p>2967 3/8" to 10mm nylon fuel line</p> 	<p>2971 3/8" 90° to 10mm nylon fuel line.</p> 	<p>2972 3/8" 90° to 8mm nylon fuel line.</p> 	<p>2973 1/4" to 8mm / 5/16" nylon fuel line</p> 
<p>2974 5/16" to 10mm nylon fuel line.</p> 	<p>2978 3/8" to 10mm nylon fuel line.</p> 	<p>2979 5/16" to 8mm / 5/16" nylon fuel line.</p> 	<p>3153C 5/16" - 90° to 8mm nylon fuel line</p> 	<p>3154C 3/8" - 90° to 10mm nylon fuel line</p> 
<p>3155C 5/16" - 90° to 10mm nylon fuel line.</p> 	<p>3156C 5/16" 45° to 8mm 5/16" nylon fuel line</p> 	<p>3157C 3/8" 45° to 10mm nylon fuel line</p> 	<p>3310 12mm to 1/2" tubing.</p> 	<p>3311 12mm - 90° to 1/2" tubing.</p> 
<p>3312 1/2" - to 1/2" tubing.</p> 	<p>3313 1/2" - 90° to 1/2" tubing.</p> 	<p>3314 5/8" to 5/8" tubing.</p> 	<p>3315 5/8" - 90° to 5/8" tubing.</p> 	<p>3316 5/8" - 45° to 5/8" tubing.</p> 

Stainless Steel Quick Connector



Part #	Size
2996	3/8"
4229	5/16"
4222	1/4"

Straight & 45° Steel Quick Connectors



Part #	Size
3093H	5/16"
3094H	5/16" x 45°

90° Stainless Steel Quick Connectors



Part #	Female	Male
3330	5/16"	5/16"
3331	3/8"	3/8"
3332	3/8"	5/16"

FUEL LINE QUICK CONNECTORS

FUEL LINE RETAINER CLIPS

3102, 3103, 3111, 3114 	3104 	3105 	3106, 3107 	3108, 3109 	3221, 3318, 3319
3222, 3317 	3202, 3203 	3325, 3326 	3320 Ford Repair (Pink) 	3321 Ford Repair (Pink) 	3322, 3323

Part #	Description	Part #	Description	Part #	Description
3102	3/8" GM / Chrysler / Ford	3109	3/8" Release sleeve GM / Chrysler	3317	12mm Vent connector
3103	5/16" GM / Chrysler / Ford	3111	1/4" GM / Chrysler / Ford	3318	1/2" Vent Connector
3104	5/16" Ford (White)	3114	1/2" GM / Chrysler / Ford	3319	5/8" Vent connector
3105	3/8" Ford (Black)	3202	Ford Truck 13mm	3325	5/16" Steel Retainer Clip
3106	1/4" Ford	3203	Ford Truck 10.5mm	3326	3/8" Steel Retainer Clip
3107	5/16" Ford Transmission line	3221	5/16" Ford (White) New style	3320	5/16" Ford Fuel Line Clip <i>(with pop-up tab)</i>
3108	5/16" Release sleeve GM / Chrysler	3222	3/8" Ford (Black) New style	3321	3/8" Ford fuel Line Clip <i>(with pop-up tab)</i>
				3322	5/16" Ford Fuel Line Clip
				3323	3/8" Ford Fuel Line Clip (Red)

GM COOLANT LINE QUICK CONNECTOR



4202	5/8" Heater hose connector General Motors 3.1, 3.4, 5.7 '90 and up (Corvettes only 6.2)
4203	3/4" Heater hose connector General Motors Astro & Safari '90 and up

COOLANT RETAINER CLIPS

4243	3/4" Coolant line retainer clip (Used with part #'s 4203, 4205, 4215)	
4244	5/8" Coolant line retainer clip (Used with part # 4204)	
4242	5/8" Coolant line retainer clip (Used with part # 4202)	
3114	1/2" Coolant line retainer clip	

NYLON COOLANT LINE QUICK CONNECTOR



90° Elbow

4201	5/8" coolant 90° quick connector Ford & Mazda truck '90 and up <i>(Use with Part # 2990 360° Seal Clamps)</i>
4215	3/4" - 90° Elbow quick connector Ford & Mazda Trucks '90 and Up <i>(Use with Part # 2995 360° Seal Clamps)</i>

Straight

4204	5/8" Straight quick connector Ford & Mazda truck '90 and up <i>(Use with Part # 2990 360° Seal Clamps)</i>
4205	3/4" Straight quick connector Ford & Mazda Trucks '90 and up <i>(Use with Part # 2995 360° Seal Clamps)</i>

GM COOLANT LINE CONNECTORS

Part # 4235		Part # 4249	
	5/8" Heater hose connector (Replacement for O.E.M Plastic Connectors) GM 3.1 engines		Water pump hose pipe connector 3/8" pipe thread to 5/8" hose

HOSE BARB TO PIPE THREAD CONNECTORS

Part #	Hose I.D	Pipe Thread
4275	1/4"	1/8"
4276	1/4"	1/4"
4277	3/8"	1/8"
4278	3/8"	1/4"
4279	3/8"	3/8"
4280	1/2"	3/8"



HEATER HOSE JOINERS

2794	1/2" Heater hose joiner	
2795	5/8" Heater hose joiner	
2796	3/4" Heater hose joiner	
2797	5/8" to 3/4" Heater hose reducer joiner	

TRANSMISSION QUICK CONNECTORS

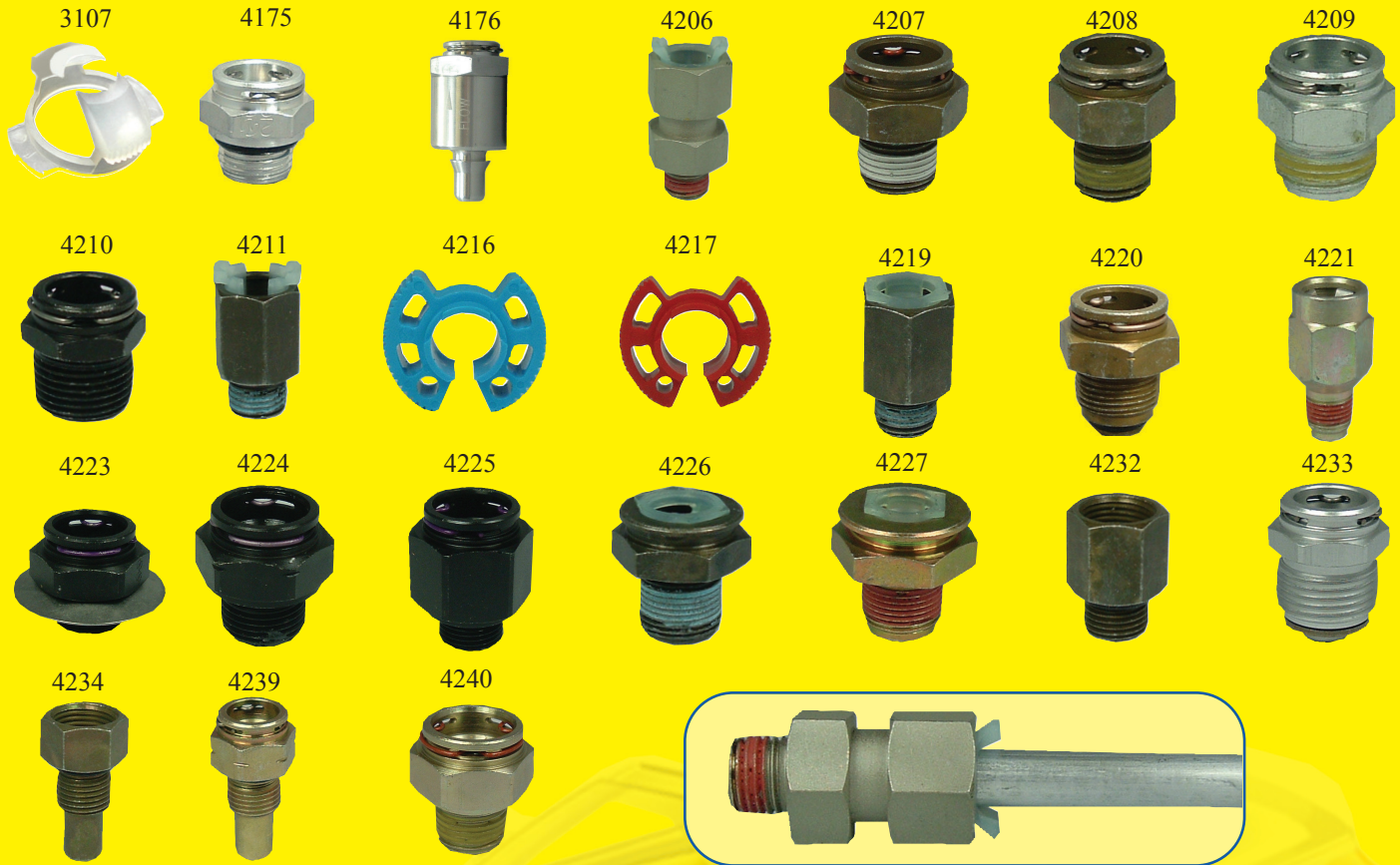

Part # Description

- 3107 Retainer Clip for 4219
- 4175 3/8" Transmission Quick Connector
- 4176 3/8" In-Line Transmission Filter (Installs at the cooler outlet)
- 4206 3/8" Transmission Quick Connector 1982 - Up (Ford)
- 4207 Steel Quick Connector 1/2" Tube x 3/8" NPTF GM Trucks G, C/K 1996 - Up
- 4208 Steel Quick Connector 3/8" Tube x 1/4" -18 NPS GM Trucks S/T, C/K, Astro, Safari 1996 - Up
- 4209 Steel Quick Connector 3/8" Tube x 5/8" NPTF GM Trucks S/T, C/K, Astro, Safari with Body 1998 - Up
- 4210 Steel Quick Connector 3/8" Tube x 3/8" NPTF GM Trucks S/T, Astro, Safari 1996 - Up
- 4211 5/16" Transmission Quick Connector 1982 - Up
- 4216 3/8" Quick Disconnect Tool for Transmission & Oil Cooler Lines (Part #'s 4208,4209,4210,4233,4239)
- 4217 1/2" Quick Disconnect Tool for Transmission & Oil Cooler Lines (Part #'s 4207,4220)
- 4219 5/16" Quick Connector (GM & Chrysler)
- 4220 GM Engine Oil Cooler Steel Quick Connector 1/2" Tube x 20mm - 1.5 (All rear wheel drive Trucks)
- 4221 Transmission Quick Connector (Chrysler)
- 4223 GM Truck Radiator Transmission Quick Connector 5/8" Tube x 7/8 -14 UNF (Silverado, Sierra, Tahoe, Yukon, Suburban, Avalanche, Escalade EXT & ESV 1999 - Up)
- 4224 GM Truck Transmission Quick Connector 5/8" Tube x 7/8" -14 UNF (Silverado, Sierra, Tahoe, Yukon, Suburban, Avalanche, Escalade EXT & ESV 1999 - Up)
- 4225 GM Truck Transmission Quick Connector 5/8" Tube x 3/4" - 16 UNF (Silverado, Sierra, Tahoe, Yukon, Suburban, Avalanche, Escalade EXT & ESV 1999 - Up)
- 4226 3/8" Transmission Quick Connector 11/16" - 20 UNF - 2 A Thread
- 4227 5/16" Transmission Quick Connector 5/8" - 20 UN - 2A Thread
- 4232 3/8" Invert Flare Female Transmission Oil Cooler Line Quick Connector with External O-Ring Seal 1994 - Up
- 4233 3/8" Tube x 18mm x 1.5 Aluminum Transmission Quick Connector 1998 - Up
- 4234 3/8" Invert Flare Female Transmission Oil Cooler Line Adapter
- 4239 3/8" Invert Flare Female Transmission Oil Cooler Line Quick Connector with External O-Ring Seal 1994 - Up
- 4240 GM Truck Transmission Quick Connector 5/8" Tube x 1/2" NPTF Duramax Diesel 2000 - Up

**4176 - In-Line Transmission Filter
Connects at the cooler outlet**



Always install after transmission rebuild or replace.

- | Part # | Description |
|--------|---|
| 4246 | 3/8" Retainer Clip (for 4208, 4209, 4210, 4233) |
| 4247 | 1/2" Retainer Clip (for 4207, 4220) |
| 4248 | 5/8" Retainer Clip (Truck) |



TRANSMISSION REPAIR LINES & FITTINGS

PLASTICOL 3000

POWER STEERING & TRANSMISSION LINE STEEL TUBE NUTS



TRANSMISSION REPAIR & REPLACEMENT TUBING

25' COILS

Replace rusted & leaking steel transmission lines with FMSI's **Plasticool 3000**

Part #	Description
4463-25	3/8" x 25' Plasticool 3000
4462-25	5/16" x 25' Plasticool 3000











Part #	Tube Size	Thread Diameter	Thread Pitch
3434	3/8"	16mm	1.5 (Blue)
3435	3/8"	16mm	1.5 (Gold)
3436	3/8"	18mm	1.5 (Blue)
3438	3/8"	18mm	1.5 (Gold)
3442	3/8"	5/8"	18 TPI (Gold)
3443	5/16"	5/8"	18 TPI (Red)
3462	1/4"	9/16"	18 TPI (Silver)
3464	3/8"	16mm	1.5 (Black)
3489	5/16"	1/2"	20 TPI

UNIVERSAL TRANSMISSION FITTINGS

Part #	Description
3418	5/16" female to 3/8" male invert flare.
3419	3/8" female to 5/16" male invert flare.

TRANSMISSION PAN DRAIN PLUGS & DIFFERENTIAL PLUGS

 <p>Part # 1024 1/2" Square Drive 9/16"</p>	 <p>Part # 1025 1/2" 3/8" internal drive</p>	 <p>Part # 1026 Chrysler Differential Plug</p>
 <p>Part # 1057 18mm x 1.5 Toyota # 90341-18016</p>	 <p>Part # 1058 18mm x 1.5 Toyota # 90341-18006</p>	 <p>Part # 1059 10mm x 1.5 Toyota # 90341-10012 Lexus # 90341-10006 Jeep # 83504041</p>
 <p>Part # 1064 7/8" - 14 Ford Diesel Transmission</p>	 <p>Part # 1060 Transmission Fluid Drain Plug 32mm x 1.5 Honda #90066-PC8-010</p>	 <p>Part # 1067 12mm X 1.75 Allison Transmission Drain Plug</p>

TRANSMISSION STEEL REPAIR LINES WITH HOSE CONNECTION



Part #	Description	Style
3182	3/8" x 4" with 18mm x 1.5 tube nut (Uses Part # 3436) Blue nut	A
3183	3/8" x 4" with 16mm x 1.5 tube nut (Uses Part # 3434) Blue nut	A
3184	3/8" x 4" with 16mm x 1.5 tube nut (Uses Part # 3435) Gold nut	B
3185	3/8" x 3 3/4" with 5/8" - 18 T.P.I. tube nut (Uses Part # 3442) Gold nut	B
3186	5/16" x 4" with 5/8" - 18 T.P.I. tube nut (Uses Part # 3443) Red nut	C
P572TF	5/16" x 72" GM Transmission Line With Special Flare	D
P672TF	3/8" x 72" GM Transmission Line With Special Flare	D
3187	5/16" x 4" with 14mm x 1.5 tube nut (Uses Part # 3009) Green nut	E
3189	3/8" x 3 3/4" male end for quick connector	F
3489K	5/16" x 4 female nut 1/2" - 20 t.p.i	G
3490K	3/8" x 4 female nut 1/2" - 20 t.p.i	G
4253	3/8" x 3 3/4" Special flare (Used with Part #'s 4208, 4209, 4210, 4233, 4234)	H
4254	3/8" x 3 3/4" x 90° Elbow special flare Used with Part #'s (4208, 4209, 4210, 4233, 4234)	K
4518	3/8" x 3 3/4" with 3/8" Tube Nut & Ridge Bead	I
4519	3/8" x 3 3/4" with 16mm Tube Nut & Ridge Bead	I
4520	5/16" x 3 3/4" with 14mm Tube Nut & Ridge Bead	I
4521	5/16" x 3 3/4" - 5/16" Tube Nut & Ridge Bead	I
4522	5/16" x 90° - 1/2"-20 O-ring flare	L
4523	5/16" x 90° - 14mm x 1.5 O-ring flare	M

HIGH PRESSURE POWER STEERING & TRANSMISSION REPAIR LINES & FITTINGS



A
B
C
D
E
F
G
K
I

*High Pressure Compression Union (5000 psi)
Attaching hardware included where shown*

NEW

Part #	Description	Style
4501R	3/8" x 4" with 18mm x 1.5 (3436 tube nut blue)	A
4502R	3/8" x 4" with 16mm x 1.5 (3434 tube nut blue)	A
4503R	3/8" x 4" with 16mm x 1.5 (3435 tube nut gold)	B
4504R	3/8" x 4" with 5/8" - 18mm (3442 tube nut gold)	B
4505R	5/16" x 4" with 5/8"-18mm (3443 tube nut red)	C
4506R	5/16" x 4" with 14mm x 1.5 (3009 tube nut Olive)	D
4507R	3/8" x 4" with GM Transmission male end for quick connect	E
4509R	3/8" x 4" x 90° with GM Transmission male end for quick connect	K
4511R	3/8" x 4" Ridge bead	F
4512R	5/16" x 4" Ridge bead	F
4515R	3/8" x 4" - 5/8" - 18 Invert flare	I
4516R	5/16" x 4" - 1/2"-20 Invert flare	I

POWER STEERING, TRANSMISSION METRIC ADAPTERS

Part #	Female	Male
3466	3/8" Tube (5/8" Thread)	16mm x 1.5 GM
3467	3/8" Tube (5/8" Thread)	14mm x 1.5 GM
3468	3/8" Tube (5/8" Thread)	18mm x 1.5 GM
3469	3/8" Tube (5/8" Thread)	11/16" - 18 Ford



CUPRO POWER REPAIR LINES

POWER STEERING RACK REPAIR LINES



Part #	Description
4531	5/16" x 30" with invert Flare
4532	5/16" x 30" with O-Ring Flare
4535	5/16" x 30" Universal Repair Line
4533	3/8" x 30" with invert Flare
4534	3/8" x 30" with O-Ring Flare
4536	3/8" x 30" Universal Repair Line
4537	1/4" x 30" Universal Repair Line

CUPROPOWER
Repair lines are easy bend and are guaranteed for the life of the vehicle.
High pressure compression union included



POWER STEERING RACK LINE REPAIR ASSORTMENT # 0128

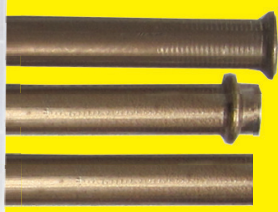

NEW

ASSORTMENT # 0128
Includes (7) 30" Cupro Nickel Repair lines with flares

40 pieces

OIL DRAIN PLUGS

 <p>Part # 1001 Hex head washer face GM 1/2" x 20 T.P.I</p> <p>Hex 9/16" Washer Face .566" Overall Length 1.064" Under head Length .691"</p>	 <p>Part # 1002 Hex head washer face Ford 14mm x 1.5</p> <p>Hex 1/2" Washer Face .904" Overall Length 1.017" Under head Length .606"</p>	 <p>Part # 1003 Hex head washer face GM 12mm x 1.75</p> <p>Hex 15mm Washer Face .22mm Overall Length 36.64mm Under head Length 24.72mm</p>
 <p>Part # 1004 Piggyback "A" 1/2" Oversize</p>  <p>Part # 1005 Piggyback "AA" 1/2" Oversize</p>	 <p>Part # 1006 - "A" 1/2" Oversize</p>  <p>Part # 1007 - "AA" 1/2" Oversize</p>  <p>Part # 1008 - "AAA" 1/2" Oversize</p>	 <p>Part # 1009 Hex head washer face Nissan 16mm x 1.5</p> <p>Hex 19mm Washer Face 26.36mm Overall Length 25.56mm Under head Length 12.17mm</p>
 <p>Part # 1010 Hex head washer face Toyota 18mm x 1.5</p> <p>Hex 19mm Washer Face 28.32mm Overall Length 25.41mm Under head Length 11.47mm</p>	 <p>Part # 1011 Hex head washer face Honda/Subaru 20mm x 1.5</p> <p>Hex 17mm Washer Face 27.07mm Overall Length 26.29mm Under head Length 13.84mm</p>	 <p>Part # 1012 Hex head washer face Nissan/Volvo 16.4mm x 1.33</p> <p>Hex 19mm Washer Face 26.28mm Overall Length 25.66mm Under head Length 11.78mm</p>
 <p>Part # 1013 Internal drive washer face Mercedes, Audi, Volkswagen 26mm x 1.5</p> <p>Hex int hex 34.30mm Overall Length 18mm Under head Length 14.47mm</p>	 <p>Part # 1014 Hex head washer face Nissan/Toyota 12mm x 1.25</p> <p>Hex 14mm Washer Face 19.72mm Overall Length 26.68mm Under head Length 17.03mm</p>	 <p>Part # 1017 Hex head Volkswagen 14mm x 1.5</p> <p>Hex 19mm Washer Face - Overall Length 24.02mm Under head Length 13.66mm</p>
 <p>Part # 1020 Hex head Repair Plug 14mm x 1.5 Oversize</p> <p>Hex Washer Face Overall Length Under head Length</p>	 <p>Part # 1021 Hex head Repair Plug 12mm x 1.25 Oversize</p> <p>Hex Washer Face Overall Length Under head Length</p>	 <p>Part # 1022 Hex head Repair Plug 12mm x 1.75 Oversize</p> <p>Hex Washer Face Overall Length Under head Length</p>
 <p>Part # 1027 Hex head washer face Ford 14mm x 1.5</p> <p>Hex 5/8" Washer Face 25.27mm Overall Length 31.91mm Under head Length 21.14mm</p>	 <p>Part # 1028 Hex head molded washer face Chrysler 1/2" x 20 T.P.I</p> <p>Hex 5/8" Washer Face 1.101" Overall Length 1.293" Under head Length .816"</p>	 <p>Part # 1029 Hex head washer insert Saturn 12mm x 1.75</p> <p>Hex 14mm Washer Face 31.60mm Overall Length 33.77mm Under head Length 18.50mm</p>
 <p>Part # 1030 Hex head washer face Jeep 14mm x 1.25</p> <p>Hex 13mm Washer Face 22.55mm Overall Length 26.43mm Under head Length 16.65mm</p>	 <p>Part # 1032 Hex head molded washer face Dodge 14mm x 1.5</p> <p>Hex 17mm Washer Face 27.94mm Overall Length 29.99mm Under head Length 16.92mm</p>	 <p>Part # 1033 Hex head washer insert Ford 14mm x 1.50</p> <p>Hex 16mm Washer Face 27.65mm Overall Length 33.98mm Under head Length 20.00mm</p>
 <p>Part # 1034 Hex head washer insert Ford 12mm x 1.75</p> <p>Hex 15mm Washer Face 26.06mm Overall Length 37.62mm Under head Length 24.25mm</p>	 <p>Part # 1039 Hex head nylon insert magnetic tip GM 12mm x 1.75</p> <p>Hex 15mm Washer Face 26.10mm Overall Length 43.23mm Under head Length 29.43mm</p>	 <p>Part # 1040 Hex head washer insert Ford 4.0 14mm x 1.5</p> <p>Hex 13mm Washer Face 28.77mm Overall Length 33.95mm Under head Length 20.46mm</p>
 <p>Part # 1041 Hex head washer face Magnetic tip 14mm x 1.5</p> <p>Hex 13mm Washer Face 23.04mm Overall Length 30.00mm Under head Length 19.66mm</p>	 <p>Part # 1044 Hex head with gasket BMW 12mm x 1.5</p> <p>Hex 11/16" Washer Face - Overall Length 26.06mm Under head Length 18.64mm</p>	 <p>Part # 1045 Hex head washer face Honda, Acura 14mm x 1.5</p> <p>Hex 17mm Washer Face 24.31mm Overall Length 21.42mm Under head Length 10.76mm</p>
 <p>Part # 1046 Hex head washer face Mercedes 14mm x 1.5</p> <p>Hex 13mm Washer Face 18.75mm Overall Length 33.32mm Under head Length 23.87mm</p>	 <p>Part # 1047 Internal drive Dodge Cummins Diesel 22mm x 1.5</p> <p>Hex int. square 33.56mm Washer Face 22.08mm Overall Length 18.75mm Under head Length</p>	 <p>Part # 1048 Hex head molded washer face Ford 12mm x 1.75</p> <p>Hex 15mm Washer Face 26.56mm Overall Length 39.74mm Under head Length 27.10mm</p>
 <p>Part # 1049 Hex head washer insert Ford 12mm x 1.75</p> <p>Hex 13mm Washer Face 26.66mm Overall Length 35.82mm Under head Length 24.22mm</p>	 <p>Part # 1050 Internal drive GM Catera 14mm x 1.5</p> <p>Hex int. hex 25.44mm Washer Face 13.38mm Overall Length 9.78mm Under head Length</p>	 <p>Part # 1051 Hex head washer face w/ gasket 14mm x 1.5</p> <p>Hex 3/4" - 19mm Washer Face 24.72mm Overall Length 27.95mm Under head Length 15.41mm</p>
 <p>Part # 1052 Universal drain plug (not for Honda & VW)</p> <p>Hex Washer Face Overall Length Under head Length</p>	 <p>Part # 1053 Internal drive molded washer face Dodge Cummins Diesel 18mm x 1.5</p> <p>Hex int. square 31.03mm Washer Face 24.26mm Overall Length 19.41mm Under head Length</p>	 <p>Part # 1054 Hex head washer insert Chrysler 14mm x 1.5</p> <p>Hex 13mm Washer Face 28.73mm Overall Length 33.67mm Under head Length 21.00mm</p>
 <p>Part # 1055 Hex head w/ integral washer Volkswagen 14mm x 1.5</p> <p>Hex 19mm Washer Face - Overall Length 30.00mm Under head Length 22.86mm</p>	 <p>Part # 1061 Hex head molded washer face Ford 10mm x 1.5</p> <p>Hex 13mm Washer Face 26.65mm Overall Length 37.82mm Under head Length 24.77mm</p>	 <p>Part # 1062 Hex head molded washer face GM/AMC 12mm x 1.75</p> <p>Hex 15mm Washer Face 26.58mm Overall Length 32.67mm Under head Length 21.00mm</p>
 <p>Part # 1063 Hex head molded washer face Chrysler 14mm x 1.5</p> <p>Hex 1/2" Washer Face 27.72mm Overall Length 30.44mm Under head Length 19.50mm</p>	 <p>Part # 1065 Oil Pan Plug Honda/Acura 14mm x 1.5 *(Long)</p> <p>Hex Washer Face Overall Length Under head Length</p>	 <p>Part # 1068 Toyota/ Nissan Oil Drain Plug 12mm x 1.75</p> <p>Hex 14mm Washer Face 19.70mm Overall Length 22mm Under head Length 12.50mm</p>
 <p>Part # 1069 Nissan Oil Drain Plug 12mm x 1.25</p> <p>Hex 15mm Washer Face 26mm Overall Length 38mm Under head Length 24mm</p>	 <p>Part # 1070 General Motors Oil Drain Plug 12mm x 1.75</p> <p>Hex 14mm Washer Face 22.35mm Overall Length 22mm Under head Length 11mm</p>	 <p>Part # 1071 Oil Drain Plug 5/8"-18</p> <p>Hex 13mm Washer Face 23mm Overall Length 23mm Under head Length 13mm</p>

DRAIN PLUG GASKETS

Steel & Viton
General Motors



OE Rubber
GM, Ford, Chrysler



Steel & Rubber



Double Fiber



Nylon



Copper Fiber



Copper



Fiber



Aluminum



OE Rubber
Chrysler



Teflon® Coated Fiber
Toyota



Copper Fold Over



Part #	Size	Style	Part #	Size	Style	Part #	Size	Style	Part #	Size	Style	Part #	Size	Style
2001	1/2"	E	2111	12mm	D	2126	14mm	A	2005	18mm	E	2107	22mm	H
2051	1/2"	F	2124	12mm	C	2134	14mm	B	2055	18mm	F	2130	22mm	A
2076	1/2"	G	2125	12mm	A	2135	14mm	B	2080	18mm	G	2157	22mm	I
2085	1/2"	G	2132	12mm	B	2137	14mm	J	2105	18mm	H	2140	7/8"	B
2101	1/2"	H	2136	12mm	K	2153	14mm	I	2112	18mm	D	2159	24mm	I
2125	1/2"	A	2138	12mm	B	2160	14mm	I	2128	18mm	A	2108	25mm	H
2151	1/2"	I	2152	12mm	I	2004	16mm	E	2162	18mm	I	2165	25mm	I
2164	10mm	L	2161	12mm	I	2054	16mm	F	2006	20mm	E	2058	26mm	F
2002	12mm	E	2003	12mm	E	2079	16mm	G	2056	20mm	F			
2051	12mm	F	2053	12mm	F	2104	16mm	H	2081	20mm	G			
2077	12mm	G	2078	12mm	G	2127	16mm	A	2106	20mm	H			
2102	12mm	H	2103	14mm	H	2154	16mm	I	2156	20mm	I			

STANDARD & METRIC GREASE FITTINGS

Assortments 0428 (Standard) 0429 (Metric)

2500 1/4" - 28- Straight	2502 1/4" - 28 - 45°	2503 1/4" - 28 - 90°	2504 6mm x 1.0 Straight
2505 6mm x 1.0 x 45°	2506 6mm x 1.0 x 90°	2507 8mm x 1.0 Straight	2508 8mm x 1.0 x 45°
2509 8mm x 1.0 x 90°	2510 1/8" Pipe Thread	2511 1/8"-45° Pipe Thread	2512 1/8" - 90° Pipe Thread

CABIN AIR FILTER HARDWARE

Assortments 0364

4101	4102	4103	4104
4105	4106	4107	4108
4109	4110	4111	4112

Ergo Tuflok Assortments



NEW

8620 - 280 pieces
GM Rocker panel Clips



8637 - 280 pieces
Large Assortment



8180 - 110 pieces
Small Assortment

Complete Problem Solving Automotive Hardware

GREASE FITTINGS - ERGO TUFLOKS 20

For Application guide contact: 1-800-651-7445 or Email us at info@fmsiinc.com



NEW

GREASEABLE

6375(Right) - 6376 (Left)

'99-06 Silverado, Sierra, 2000 Yukon SLE,
'00-05 Tahoe, '00-06 Suburban, '01-04
Yukon Denali, '02 Yukon, 02-06 Avalanche,
Escalade, '05-'06 Yukon S, 2007 Silverado
Classic, Sierra Classic SLE



NEW

6377

2007-2011 Chevrolet Silverado
2007-2011 GMC Sierra
(Complete Door)



NEW

GREASEABLE 6378

2007-2011 Chevrolet Silverado
2007-2011 GMC Sierra
(Complete Door)



NEW

GREASEABLE 6379

'88-95 Jeep Wrangler (YJ) 1/2 Door
'97-06 Jeep Wrangler (YJ) '04-06
Jeep Wrangler Unlimited
(Complete Upper & Lower)

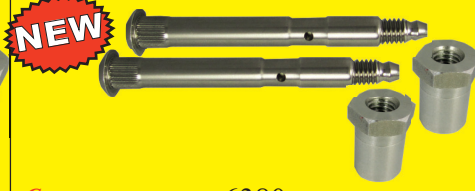

NEW

GREASEABLE 6380

'88-95 Jeep Wrangler (YJ) 1/2 Door
'97-06 Jeep Wrangler (YJ) '04-06
Jeep Wrangler Unlimited
(Complete Tailgate)

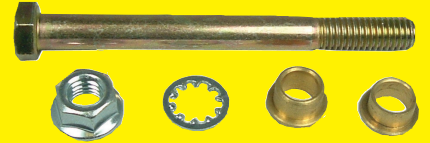

94DPU

'94-2000 Dodge Ram Pick-up Trucks
1/2, 3/4 & 1 Ton (with 3/8" Pin)



Part # 99CPU (Single Hinge)

99CPU4 (Door Kit)

'96-2006 Chevy Silverado, GMC Sierra,
Suburban, Yukon



GREASEABLE 6354

'96-2012 General Motors Savana & Express
Vans Side Cargo Doors (Left or Right sides)



GREASEABLE 6355

'96-2012 General Motors Savana & Express
Vans Side Cargo Doors (Left or Right sides)

DOOR PINS & BUSHINGS

6300 Length 4 1/16" Dia. 11/32" Head O.D. 9/16" GM	
6301 Length 4" Dia. 11/32" Head O.D. 7/16"	
6307 Length 5 1/2" Dia. 11/32" Shoulder O.D. 3/8" Head O.D. 9/16"	
6340 Length 4 1/8" Dia. 11/32" Shoulder O.D. 3/8" Head O.D. 1/2" GM Trucks	
6350 Length 3 1/2" Dia. 11/32" Knurl Dia. .358" Head O.D. 9/16" Ford Trucks	

6308 O.D. 27/64" I.D. 11/32" Height 19/64" Flange O.D. 19/32" GM, Ford & Trucks	
6310 O.D. 31/64" I.D. 11/32" Height 23/64" Flange O.D. 19/32" GM & GM Trucks	
6313 O.D. 31/34" I.D. 11/32" Height 19/64" Flange O.D. 19/32" Ford	
6315 O.D. 1/2" I.D. 11/32" Height 23/64" Flange O.D. 43/64" GM	
6316 O.D. 17/32" I.D. 25/64" Height 23/64" Flange O.D. 11/16" GM	
6331 O.D. 9/16" I.D. 21/64" Thickness 1/64" GM Trucks	

Brake Lathe Cutting Tips

Standard Packaging of 10 pieces (Unless Noted)

 <p>060-10 ACCUTURN models 8911, 8922, 8944, 8989, 8991, & 8993 11° angle, 1/64" radius</p>	 <p>061-10S PRO-CUT models 610 on car lathe YBG models 600 & 610 on car lathe</p>
 <p>062-10 AMMCO Models 1000, 1001, 3000, 4000, 4100, 7000, 7700 & 700, 705, 710 ALLTOOL model 747 RELS model 2000 FMC model 500 RTI on car lathe PERFORMANCE model 7850 & on car lathes 66, 6600, 7100, 7200, 7600 RTI model BRC-35 on car lathe HUNTER model BL500 STAR model 1176</p>	 <p>062-10TH BEAR models 1478 disc lathe, 1410, 1467, 1468 & 1469 drum lathe RJ WEST (PERFECT HOFFMAN) models 300, 350, 450, 915 & 915 HD Drum</p>
 <p>062-10TH ROUND CUTTING TIP used in place of 062-10 and 802-10 cutting tips Must use with # 428 Tool holder. (Extra-long life)</p>	 <p>103-10 AMMCO MODELS 3850 & 3860 RTI MODELS BRC 35, BRC500, BRC 550, 450-80001-00 & 450-80002-00 FMC - JOHN BEAN MODEL 500 ON CAR LATHE ALL-TOOL MODEL 747 HUNTER MODEL BL500, BL605 PERFORMANCE MODEL 66, 6600, 7100, 7200 & 7600</p>
 <p>407-10 FMC - JOHN BEAN/BARRETTE .020 RADIUS MODELS 67BSD, 67DLX, 67GSA, 69DLX, 701ECF, 601PF FMC 400, 500, 600 & 700 HOFFMAN, RJ WEST TRUE CUT MODEL 400, 401 PERFECT EQUIPMENT MODEL 400, P450</p>	 <p>408-10 SAME APPLICATIONS AS 060-10 & 407-10 but .048 radius. More durable for rusted and hardened rotors.</p>
 <p>502-10 502-4 - (4 Pack) RJ WEST, HOFFMAN model 7515 drum lathe PERFECT EQUIPMENT models P300, P350 & P450 Drum lathe</p>	 <p>503-10 RJ WEST, HOFFMAN Drum lathe Hoffman model 715 Titanium Nitride Coated cutting tip.</p>
 <p>802-10 KWIKWAY / SNAP-ON models NDL, BDL, CBL & KWIK LATHE on car lathe 108-005-04, SDL & DL ROTUNDA model 850 disc lathe RELS model SW504 swing arm lathe SNAP-ON models YA180 & YA281</p>	 <p>903-10 VAN NORMAN 243X disc and drum lathe RELS models 204C, 204D, 204S, 205DC & 415</p>

Part No. 70B

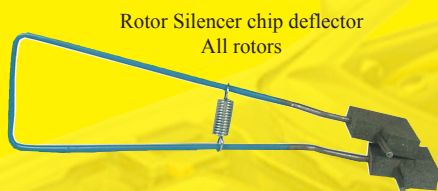





Rotor Silencer chip deflector
All rotors

Part No. 80B



Drum silencer band with long life attaching hardware Natural rubber beige.
All drums

Natural and Neoprene Rubber Silencer Bands

 <p>68B Rotor silencer band (with flat weights and flexible attaching clip) Black Neoprene excellent resistance to oil and chemicals. All rotors</p>	 <p>69 Rotor silencer band (with flat weights and flexible attaching clip) Natural rubber beige All rotors</p>	 <p>94 Rotor silencer band 9" diameter Black Neoprene Excellent resistance to oil and chemicals Solid rotors</p>	 <p>95 Rotor silencer 9" diameter Latex tubing with steel weights All rotors 95S 7" Diameter Latex tubing</p>	 <p>96 Rotor silencer band 6 1/2" diameter Black Neoprene Excellent resistance to oil and chemicals Solid Rotors</p>
--	---	--	---	--

Lubricants & Chemicals

100% Brake Silicone Compound



- OEM Style brake & Multi-purpose Lube
- Stops Seizing of caliper slides
- Non Petroleum Based
- WILL NOT WASH OFF

Part # 49592

100% Dielectric Silicone Compound

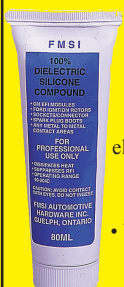

- OEM Dielectric compound
- Stops arching of electrical components
- Prevents seizing
- WILL NOT WASH OFF

Part # 49593

Brake Cleaner



- Non Chlorinated
- Removes Dirt, Grease & Brake Dust
- Does not leave residue
- Will not Damage rubber components

Part # FM720

Quik Pen Lubricant



- High strength penetrating lubricant.
- It's powerful formulation assures constant lubrication even under the most extreme conditions

Part # FM2005

Air Intake Cleaner



- Effectively cleans dirt, gum and varnish from carburetors, fuel injection throttle bodies, automatic chokes & PVC valves.

Part # FM2018

BENDING & STRAIGHTENING

NEW

Part # 5426

Brake Line tube straightener

Straighten steel tubing coils
3/16", 1/4" 5/16", 3/8", 1/2" & 5/8"

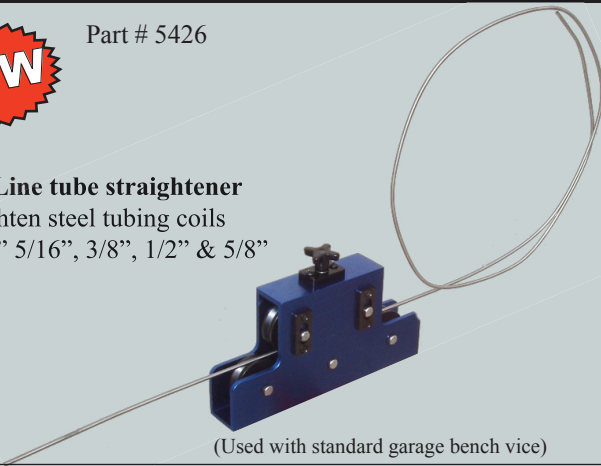

(Used with standard garage bench vice)

Part # 5402

Brake Line Tube Bender



Part # 5415



Heavy Duty brake Line Tube Bender
(3/16" 1/4", 6mm)

Part # 5416



Includes two grooved rollers
3/16" - 1/4" & 5/16" - 3/8"

Heavy Duty Tube Bender adapts to make even the most difficult bends simple and easy
(3/16" 1/4", 5/16" & 3/8") *(6mm, 8mm, 10mm)

Part # 5417



Hand Bender complete with aluminum guides for 16mm, 22mm O.D. Copper and aluminum tubing .
Bends 1/2" - 5/8" - 3/4" - 7/8" 12mm - 15mm - 16mm - 22mm

Part # 5400



Swage tool
3/16" - 1/4" - 5/16", 3/8" - 1/2" - 5/8"
Increase tube inside diameter for soldering or welding

CUTTING TOOLS & BLADES

Part # 5406

Small ratcheting tube cutter - 1/8" - 1/2" OD



Part # 5407

Large ratcheting tube cutter - 1/4" - 7/8" (6- 23mm)

Part # 5408

Tube Cutting Tool, for steel, copper, aluminum and stainless steel

Telescopic tube cutter and reamer 1/8" - 1-1/8"



Part # 5409



Replacement cutting wheels

Part # 5410



Used with Part # 5406

Used with Part # 5407 & 5408

FLARING TOOLS

Part # 5403



Hardened Double (Standard) Manual Flaring Tool

Part # 5405

Metric Hardened Bubble Flaring Tool



Tube Swage
5425

8mm
5423

10mm
5424

Part # 71475

Hydraulic Flaring Tool



Replacement pieces available Separately

Hydraulic Cylinder Repair Kit

Part # 71201RK
Repairs 71475



FUEL, TRANSMISSION & AIR CONDITIONING DISCONNECT TOOLS

Part # 3113
General Motors Fuel Line
Quick connector Release Tool



Part # 5411
Stainless Steel Wire Brush
Cleans connectors without
leaving residue



Part # 4803
Fuel & A/C
Disconnect Tool Kit



Part # 4801
Fuel and A/C Spring lok
Disconnect tool Kit
(Red, Blue, Black & Cream)



Part # 4802
Fuel & Transmission
Disconnect Tool Kit



Part # 5427
Fuel Line Pliers
Clamping range 18mm - 28mm



AIR CONDITIONING HYDRAULIC CRIMPING TOOL

Hydraulic crimp tool makes crimping barbed and beaded fittings as easy as 1 - 2 - 3 ! The light weight hand-held hydraulic press is portable and ideal for shop and field applications.

Part No.	Description
71500	Hydraulic Crimping Tool
Each 71500 Kit comes complete with the following replaceable parts	
71500-6	Die Set - # 6 (5/16")
	Die Set - # 8 (13/32") - <i>Reduced Barrier</i>
71500-8	Die Set - # 8 (13/32")
71500-10	Die Set - # 10 (1/2")
71500-12	Die Set - # 12 (5/8")
71500-6SRB	Die Set - # 6 (5/16") - <i>Reduced Barrier</i>
71500-10SRB	Die Set - # 10 (1/2") - <i>Reduced Barrier</i>
71500-12SRB	Die Set - # 12 (5/8") - <i>Reduced Barrier</i>

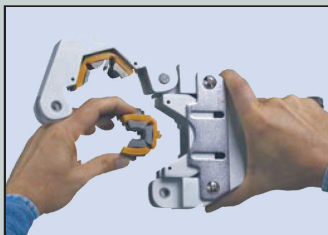

The die snaps quickly into
the press feature requiring
no tools pins or fasteners.

Part # 71500RK
Repairs 71500



AIR CONDITIONING FLUSH MACHINE

After compressor failure, A/C system components
must be flushed to ensure warranty eligibility



Part # AR6224

Start-up Flush Machine
Kit # AR6226

Contains:
AR6224 - Flush Machine
AR6225 - Adapters
AR4202 - Quick Dry Solvent

Flush Machine Adapters



2 Adapters fits most applications

Part # AR6225

Quick Dry Solvent
128oz Gallon



Part # AR4202

VACUUM PUMP

Part # 5101

Features:

- Prevents Oil Back Flow.
- Forced-feed Lubrication System (Dual-stage)
- Low Noise & Vibration
- Light Weight & Compact.

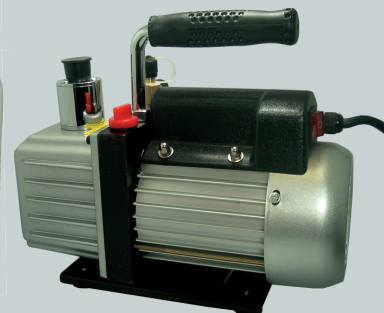

NEW

**AIR CONDITIONING REPAIR SIMPLIFIED
EXCLUSIVELY AT
FMSI Automotive Hardware**

Line Repair

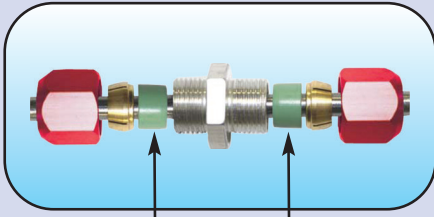

Refrigerant Leak Proof Seals

Refrigerant Leak



Rear Line Block Off

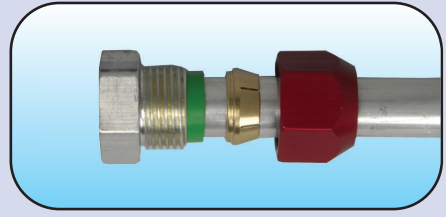

*Air Conditioning Line Repair and Rear Line Block Off
Minivans - SUV's - Trucks - Cars*

A/C Line Splice & Reducers

Part No.	Description
76000	A/C Multi Size Repair Splice 1/2", 3/8" & 5/16"
76001	A/C Line Splice 1/2"
76002	A/C Line Splice 3/8"
76003	A/C Line Splice 5/16"
76011	A/C Line Splice 5/8"
76012	A/C Line Splice 3/4"
77010	A/C Line Splice 10mm
77012	A/C Line Splice 12mm
77015	A/C Line Splice 15mm
76004	A/C Line Splice Reducer 3/8" - 5/16"
76005	A/C Line Splice Reducer 1/2" - 5/16"
76006	A/C Line Splice Reducer 1/2" - 3/8"
77103	A/C Line Splice Reducer 12mm - 10mm

Line Splice's™ unique sealing technology creates a bond that's 10 times wider than an o-ring. **A permanent repair**

Installs with an open end wrench.
On vehicle repairs
less than 10 minutes

Line Splice™ quick, profitable line repairs
and satisfied customers

Also Available, Rear Block off

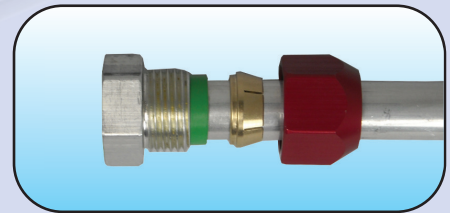

Hardware Converts a Line Splice to a Block Off

Part No.	Description
5031	O-Ring for 6050
5032	O-Ring for 6051
6050	End Cap for 76001-76003
6051	End Cap for 76011

Part No.	Description
76501	A/C Block Off Cap 1/2"
76502	A/C Block Off Cap 3/8"
76503	A/C Block Off Cap 5/16"
76504	A/C Block Off Cap 5/8"
76505	A/C Block Off Cap 3/4"
77510	A/C Block Off Cap 10mm
77512	A/C Block Off Cap 12mm
77516	A/C Block Off Cap 16mm

REPAIR LEAKING AIR CONDITIONING LINES WHILE THEY WAIT... REALLY ...

Easily repair or block off leaking Air Conditioning, Coolant, Transmission & Oil Cooler Lines with FMSI Automotive Hardware's 0117 Line splice and Block off Caps.



Assortment # 0117

Part No.	Description	Quantity
31879	Heavy Duty Thread Locker	1
5031	O-Ring for 6050 End Cap	2
5032	O-Ring for 6051 End Cap	2
6050	End Cap for 76000-76003	2
6051	End Cap for 76011	2
76000	5/16", 3/8" & 1/2" A/C Line Splice	1
76002	3/8" A/C Line Splice	1
76011	5/8" A/C Line Splice	2
5300	3/8" x 5' Aluminum Tube	1
5301	1/2" x 5' Aluminum Tube	1
5302	5/8" x 5' Aluminum Tube	1

HIGH SIDE IN-LINE A/C FILTER

Part # 76100

Protect New A/C Components from Damage!

High side filter fits 5/16", 3/8" & 1/2"

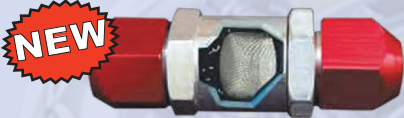

Part # 77100

High side filter fits 10mm & 12mm

- OEM Approved.
- Leak Proof performance.
- Allows for constant flow.
- Traps metallic and non metallic debris

HOSE TO TUBE REPAIR FITTINGS

Hose to tube fittings require no special tools!
Repair or replace existing aluminum lines with reduced barrier hose.

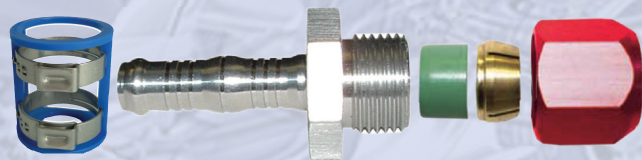

Part No.

Description

5601	5/16" Rear A/C Line Fitting
5602	3/8" Rear A/C Line Fitting
5603	1/2" Rear A/C Line Fitting
5604	5/8" Rear A/C Line Fitting

MINI VANS, SUV'S & TRUCKS REAR A/C LINE REPLACEMENT KITS



12' Reduced Barrier Hose

Hose fittings for aluminum tube replacement.

Kit includes 12' Reduced Barrier hose and attaching hardware for rear A/C Line Replacement

Kit No.

Description

5605	5/16" Rear A/C Line Replacement
5606	3/8" Rear A/C Line Replacement
5607	1/2" Rear A/C Line Replacement
5608	5/8" Rear A/C Line Replacement
5609	3/4" Rear A/C Line Replacement

RECYCLE GUARD™ SEALANT & DEBRIS SEPARATOR

Part # 72101

NEW

**INEXPENSIVE INSURANCE
AGAINST SEALANT DAMAGE!**

Superior Protection against sealant & debris with an efficient flow design for faster refrigerant recovery.



COMPRESSOR TURNER TOOL

Part # 67700

NEW

Allows manual rotation, recommended by compressor manufacturers



- Fits R, H, & V Series Compressors.
- Fits where spanner wrench won't.
- Threads into clutch hub.
- Distributes lubricant to prevent damage on start-up.

A/C PORT EXTENDER

Part # 90003



NEW

Helps reduce component R&R Time

- Fits standard high side A/C ports.
- Fits in tight spaces to extend port.
- Connects to quick connect.

PERMATUBE™ REPLACEMENT KIT

Part # 65605

Repair plastic radiator overflow tubes in minutes

NEW

- No messy glues or epoxy
- No coolant removal
- Costs less than rad replacement

BROKEN TO FIXED IN 5 MINUTES



PERMATUBE™ REFILLS

Part # 65608

NEW



Permatube™ plastic radiator overflow replacement tubes (for 65605)

R134A BARRIER HOSE

5' & 25' Foot Coils
Barrier Hose

For R134a, R12, REPLA 134, and other mobile refrigerants

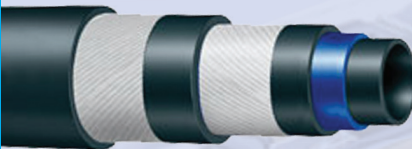

Part No.	Size
AR516	# 6 - 5/16"
AR516-5	# 6 - 5/16"
AR1332	# 8 - 13/32"
AR1332-5	# 8 - 13/32"
AR12	# 10 - 1/2"
AR12-5	# 10 - 1/2"
AR58	# 12 - 5/8"
AR58-5	# 12 - 5/8"

5' & 25' Foot Coils
Reduced Barrier Hose

For R134a, R12, REPLA 134, and other mobile refrigerants



Part No.	Size
RB516	# 6 - 5/16"
RB516-5	# 6 - 5/16"
RB1332	# 8 - 13/32"
RB1332-5	# 8 - 13/32"
RB12	# 10 - 1/2"
RB12-5	# 10 - 1/2"
RB58	# 12 - 5/8"
RB58-5	# 12 - 5/8"

UNIVERSAL HOSE TO TUBE REPAIR LINES

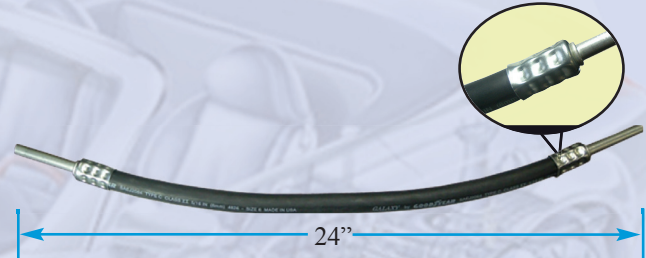

Barrier Hose

Part No.	Size
5252R	3/8" tube x # 6 hose x 24" A/C Hose to Tube Repair
5253R	1/2" tube to # 8 host x 24" A/C Hose to Tube Repair
5254R	5/8" tube to # 10 hose x 24" A/C Hose to Tube Repair
5255R	3/4" tube to # 12 hose x 24" A/C Hose to Tube Repair

Reduced Barrier Hose

Part No.	Size
5352R	3/8" tube x # 6 hose x 24" A/C Hose to Tube Repair
5353R	1/2" tube to # 8 host x 24" A/C Hose to Tube Repair
5354R	5/8" tube to # 10 hose x 24" A/C Hose to Tube Repair
5355R	3/4" tube to # 12 hose x 24" A/C Hose to Tube Repair

LOK-CRIMP HOSE TO TUBE REPAIR



Aluminum Repairs

Part No.	Hose	Tube
5381	# 6	3/8"
5382	# 8	1/2"
5383	# 10	5/8"
5384	# 12	3/4"



Steel Repairs

Part No.	Hose	Tube
5385	# 6	3/8"
5386	# 8	1/2"
5387	# 10	5/8"
5388	# 12	3/4"



Hose to Hose Repairs

Part No.	Hose
5389	# 6 - 5/16"
5390	# 8 - 13/32"
5391	# 10 - 1/2"
5392	# 12 - 5/8"



Securing Cage & Clamps

(Included with Lok-Crimp Fittings shown)

Part No.	Hose
5324HP	# 6 - 5/16"
5325HP	# 8 - 13/32"
5326HP	# 10 - 1/2"
5327HP	# 12 - 5/8"

0379M - ALUMINUM TUBING JOINER & BLOCK OFF ASSORTMENT

During assembly of a connection, the tubes to be joined are inserted into a union, up to an internal stop. The assembly tool (Part # 5131) is then used to apply pressure to the union, which compresses to complete the connection. This is a quick and simple method of joining tubes that eliminates the fire hazards of brazing and proper torque concerns of threaded connections, while producing permanent leak-free connections.

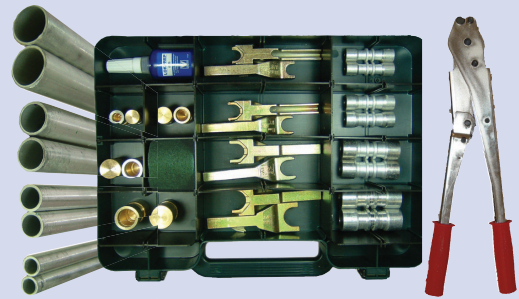

0379M - A/C Repair Assortment
Contains 35 pcs

ALUMINUM TUBE JOINING REPAIRS

Tubing Joiner Tool Part # 5131

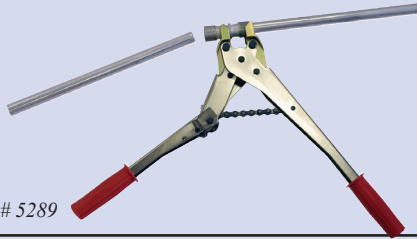

Replacement Jaw holding pin Part # 5289

Lok Prep Part # 5140

An anaerobic sealant that expands and contracts with the tube and fills grooves to ensure the integrity of the tube connection. Lok Prep must be used with every connection.

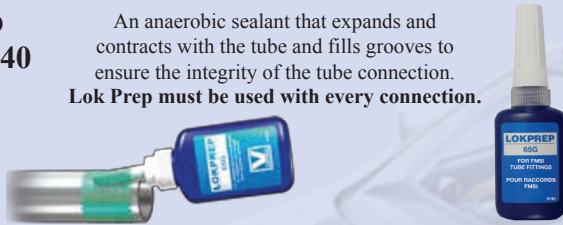

Tubing Joiner Tool Jaws

Part No.	Description
5142	5/16" (8mm)
5132	3/8" (10mm)
5133	1/2" (12mm)
5134	5/8" (14mm - 16mm)
5135	3/4" (19mm)

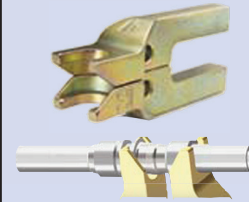

Tube Cleaning Scuff Pads Part # 5141

All tube ends must be clear of corrosion and burrs in order for a leak free connection

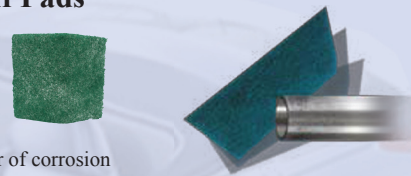

A/C TUBE HOSE CLAMPS



Part No.	Description
6001	1/4" A/C Hose Clamp
6002	3/8" A/C Hose Clamp
6003	1/2" A/C Hose Clamp
6004	5/8" A/C Hose Clamp
6005	3/4" A/C Hose Clamp

ALUMINUM TUBING

3003-0 ASTM - B483 OEM .049 Wall Thickness

5 ft Straight Lengths

Part No.	Description
5299	5/16" (8mm)
5300	3/8"
5301	1/2"
5302	5/8"
5303	3/4" (19mm)
5304	12mm
5305	16mm
5306	10mm

25 ft Coils

Part No.	Description
5309	5/16" (8mm)
5310	3/8"
5311	1/2"
5312	5/8"
5313	3/4" (19mm)
5315	12mm
5316	16mm

ALUMINUM TUBE REPAIR ENDS

36" Male Internal O-Ring to Female External O-Ring

Part No.	Hose
AA0264	3/8"
AA0265	1/2"
AA0266	5/8"
AA0267	3/4"

Cut line to repair length needed.



Male External O-Ring Tube Repair End

Part No.	Hose
5171	3/8"
5174	1/2"
5177	5/8"
5180	3/4"
5183	3/8" (16 x1.5 Nut)

Repairs condensers and hose line ends.



Male Internal O-Ring Tube Repair End

Part No.	Hose
5172	3/8"
5175	1/2"
5178	5/8"
5181	3/4"
5184	1/2" (20x1.5 Nut)
5185	3/4" (27x1.5 Nut)

Repairs condensers and hose line ends.



Female External O-Ring Tube Repair End

Part No.	Hose
5173	3/8"
5176	1/2"
5179	5/8"
5182	3/4"
5186	3/8" (16 x1.5 Nut)
5187	1/2" (20 x1.5 Nut)
5188	5/8" (22 x1.5 Nut)
5189	5/8" (24 x1.5 Nut)
5190	3/4" (27 x1.5 Nut)

Repairs condensers and hose line ends.

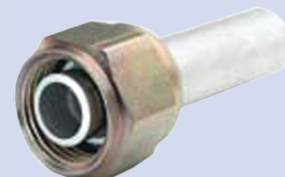

Complete Problem Solving Automotive Hardware

Aluminum Unions Standard Tube

Part No.	Size
5143	5/16" (8mm)
5136	3/8"
5137	1/2"
5138	5/8" (16mm)
5139	3/4" (19mm)



Aluminum Unions Metric Tube

Part No.	Size
5144	5/16" (8mm)
5145	3/8"
5146	1/2"
5147	5/8" (16mm)
5148	3/4" (19mm)



Steel & Copper Unions Tube

Part No.	Size
5144	5/16" (8mm)
5145	3/8"
5146	1/2"
5147	5/8" (16mm)
5148	3/4" (19mm)



Aluminum Reducer Unions

Part No.	Size
5245	1/2" to 3/8"
5246	5/8" to 1/2"
5247	3/4" to 5/8"
5374	3/8" to 5/16"



Standard 90° Elbow Unions

Part No.	Size
5290	3/8" (9.5mm)
5291	1/2" (12mm)
5292	5/8" (16mm)
5293	3/8" (19mm)



Metric 90° Elbow Unions

Part No.	Size
5294	10mm
5295	12mm
5296	15mm
5297	18mm



Aluminum 90° Elbow Unions

Part No.	Size
5394	5/16" (8mm)
5395	3/8"
5396	1/2"
5397	5/8" (16mm)
5398	3/4" (19mm)



Aluminum Tubing Block Off

Part No.	Size
5264	1/4"
5265	5/16" (8mm)
5266	3/8" (9.5mm)
5267	1/2" (12mm)
5268	5/8" (16mm)
5350	3/4" (19mm)

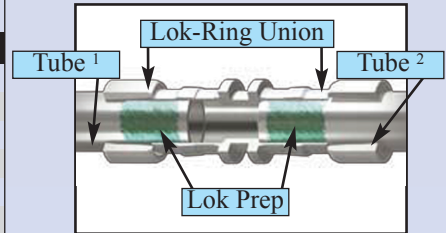

LOK-CRIMP HOSE TO TUBE REPAIR

1/2" GM Orifice Tube Repair

Part # 5256

Repairs liquid line. Install a new serviceable orifice tube at the evaporator, without replacing the complete line. (Orifice tube extra)



1/2" Ford Spring Lock Orifice Tube Repair

Part # 5269

Repairs liquid line. Install a new serviceable orifice tube, without replacing the complete line. (Orifice tube extra)



1/2" GM, Ford Orifice Tube Repair

Part # 5270

Repairs liquid line. Install a new serviceable orifice tube, without replacing the complete line. (Orifice tube extra)



GM Orifice & Lower Condenser Tube Repair

Part # 5359

1988 -1998 GM-C, K, Tahoe & Suburban W/M20 X1.5 tube nut fitting.



GM Truck Upper Condenser Repair

Part # 5270

1988 -1998 GM-C, K, Tahoe & Suburban W/M 20 x 1.5 tube nut fitting.



R134a Low Side Splice Service Port

Part No.	Size
5279	10mm
5280	12mm
5281	1/2"
5282	5/8"
5283	3/4"



R134a High Side Splice Service Port

Part No.	Size
5284	8mm
5285	3/8"
5286	10mm
5287	12mm
5288	1/2"



"T" Tap For Add-on Air Conditioning

Part No.	Size
5271	3/8"
5272	1/2"
5273	5/8"
5274	3/4"



Female Spring Lok

Part No.	Size
5450	3/8"
5454	1/2"
5458	5/8"
5466	3/4"
5462	5/8"



Female Spring Lok 90° Elbow

Part No.	Size
5452	3/8"
5456	1/2"
5460	5/8"
5468	3/4"
5464	5/8"



Male Spring Lok

Part No.	Size
5451	3/8"
5455	1/2"
5459	5/8"
5467	3/4"
5463	5/8"



Male Spring Lok 90° Elbow

Part No.	Size
5453	3/8"
5457	1/2"
5461	5/8"
5469	3/4"
5465	5/8"



Hose Lok Fitting (Standard Barrier Hose)

Part No.	Description
5471	5/16" Tube to # 6 Hose
5248	3/8" Tube to # 6 Hose
5249	1/2" Tube to # 8 Hose
5250	5/8" Tube to # 10 Hose
5251	3/4" Tube to # 12 Hose



Hose Lok Fitting (Reduced Barrier Hose)

Part No.	Description
5470	5/16" Tube to # 6 Hose
5275	3/8" Tube to # 6 Hose
5275	1/2" Tube to # 8 Hose
5276	5/8" Tube to # 10 Hose
5278	3/4" Tube to # 12 Hose



Hybrid Hose Lok Fitting (Standard Barrier Hose)

Part # 5473
5/8" Tube to # 12 Hose



Hybrid Hose Lok Fitting (Reduced Barrier Hose)

Part # 5472
5/8" Tube to # 12 Hose



Metric Hose Lok Fitting (Standard Barrier Hose)

Part No.	Description
5474	10mm Tube to # 6 Hose
5356	12mm Tube to # 8 Hose
5476	14mm Tube to # 10 Hose
5475	15mm Tube to # 10 Hose



Metric Hose Lok Fitting (Reduced Barrier Hose)

Part No.	Description
5477	10mm Tube to # 6 Hose
5357	12mm Tube to # 8 Hose
5479	14mm Tube to # 10 Hose
5478	15mm Tube to # 10 Hose



45° Hose Lok Fitting (Standard Barrier Hose)

Part No.	Description
5370	3/8" Tube to # 6 Hose
5371	1/2" Tube to # 8 Hose
5372	5/8" Tube to # 10 Hose
5373	3/4" Tube to # 12 Hose



45° Hose Lok Fitting (Reduced Barrier Hose)

Part No.	Description
5375	3/8" Tube to # 6 Hose
5376	1/2" Tube to # 8 Hose
5377	5/8" Tube to # 10 Hose
5378	3/4" Tube to # 12 Hose



90° Hose Lok Fitting (Standard Barrier Hose)

Part No.	Description
5360	3/8" Tube to # 6 Hose
5361	1/2" Tube to # 8 Hose
5362	5/8" Tube to # 10 Hose
5363	3/4" Tube to # 12 Hose



90° Hose Lok Fitting (Reduced Barrier Hose)

Part No.	Description
5365	3/8" Tube to # 6 Hose
5366	1/2" Tube to # 8 Hose
5367	5/8" Tube to # 10 Hose
5368	3/4" Tube to # 12 Hose



LOK-CRIMP HOSE TO TUBE REPAIR

Tube Lok Fitting (Standard Barrier Hose)

Part No.	Description
5252	3/8" Tube to # 6 Hose
5253	1/2" Tube to # 8 Hose
5254	5/8" Tube to # 10 Hose
5255	3/4" Tube to # 12 Hose



Tube Lok Fitting (Reduced Barrier Hose)

Part No.	Description
5352	3/8" Tube to # 6 Hose
5353	1/2" Tube to # 8 Hose
5354	5/8" Tube to # 10 Hose
5355	3/4" Tube to # 12 Hose



Standard Barrier Hose Ferrules

Part No.	Size
AC0221	# 6 to 5/16"
AC0222	# 8 to 13/32"
AC0223	# 10 to 1/2"
AC0224	# 12 to 5/8"

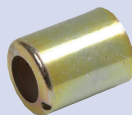

Reduced Barrier Hose Ferrules

Part No.	Size
AC0217	# 6 to 5/16"
AC0218	# 8 to 13/32"
AC0219	# 10 to 1/2"
AC0220	# 12 to 5/8"

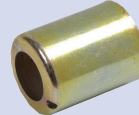

Oversized Barrier Hose Ferrules

Part No.	Size
CR6306	# 6 to 5/16"
CR6308	# 8 to 13/32"
CR6310	# 10 to 1/2"
CR6312	# 12 to 5/8"



Rapid-Seal™ AIR CONDITIONING RAPID SEAL ASSORTMENT

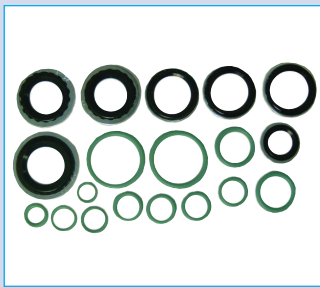

PART # MT2540
General Motors

Buick Century '97-'04, Cadillac Seville' 98-'04, Chevrolet Corvette '97-'04, Lumina '97-'01, Monte Carlo '95-'05, Oldsmobile Alero '99-'04, Aurora '95-'04, Cutlass '93-'99, Intrigue '98-'02, Pontiac Grand Prix '97-'05.

Call for complete Application
guide for all of our
Rapid Seal Kits

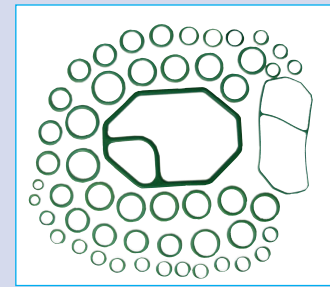
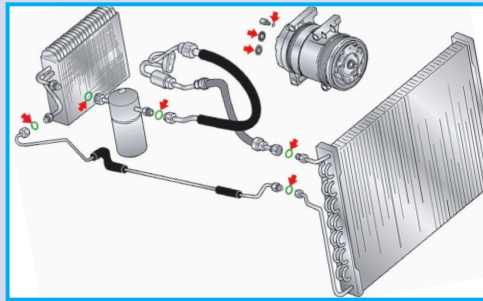

PART # MT2560
Honda, Acura, Isuzu

Acura(all models) '94 - '05, Honda (all models except Passport) '94-'05, Isuzu Amigo '94-'2000, Axiom '02-'04, Oasis '96-'99, Rodeo '98-'04, Trooper '98-'02, Vehcicross '99-'01.

COMPLETE AC COVERAGE FOR 96% OF ALL VEHICLES IN NORTH AMERICA

All the seals & o-rings in one bag, to complete the job, including SUV & Van rear air applications.

RAPID SEAL MASTER ASSORTMENT # 0466

All seals to complete the job. One rapid seal pack with each repair work order. 1985 to present applications. Increase your sales & profits, and reduce your comebacks. All gaskets and washers needed for each vehicle in one bag. *Including rear air applications.*



CONTAINS RAPID SEAL KITS FOR:

CHRYSLER, JEEP, GM, SATURN, FORD, HONDA, ACURA, NISSAN, INFINITI, SUBARU, HYUNDAI, ISUZU, MAZDA, MITSUBISHI, TOYOTA, LEXUS, AUDI/VW, BMW, MERCEDES, VOLVO.

SEALING WASHERS, GASKETS, SERVICE PORTS & CAPS

Compressor Sealing Washers

Part # 5107 5/8" Black	Part # 5108 5/8"Thin	Part # 5109 3/4"Thin	Part # 5110 5/8" Green	Part # 5111 5/8" Red	Part # 5112 5/8" Gold
Part # 5113 5/8" Thin	Part # MT0395-10 # 10-15mm Slim-Line	5114 (Short) 5115 (Long) Pilot Bushings	Part # 5242 8mm Slim-Line	Part # 5243 11mm Slim-Line	Part # 5244 17mm Slim-Line

High & Low Side Service Port Caps

5042 High Side	MT0067-5 High Side M10-1.25	MT0068-5 High Side M10-.75	MT0106-5 Primary Black M8-1.0	MT0311-5 High Side M10-1.25
5043 Low Side	MT0061-5 Low Side M8-1.0	MT0062-5 Low Side M8-1.0	MT0310-5 Low Side M9-1.0	MT0348-10 Low Side M8-1.0

Ford Sealing Washers

MT1299 Discharge Kit	5097 Valve Core Installation & Removal Tool	5091 Port Thread Cleaner 3/16" - 1/4"
MT1343 Suction Kit		

R134a Refrigerant Ports

5118 Chrysler High Side	5119 Chrys/Ford/High Side	5116 GM High Side	5117 Chrys/Ford/Merc	5120 Chrys/Ford/ Low side
5121 GM Low side	5122 GM High side	5123 Chrys/Ford/ Low side	5124 Chrys/Ford/High side	5125 Ford High side

Refrigerant Valve Cores & Tools

5044 Universal Standard	5045 GM High Flow	Part # 5102 High Flow JRA
5103 STV/POA/VIR	5104 High Flow Eaton 13mm SSV	Part # 5105 Eaton 16mm SSV

R134A ADAPTERS, FILTERS & GAUGES

R134A ADAPTERS & FILTERS

R134A ADAPTERS & CONVERTERS



Part No.	Description
MT0431	1/4" Male to 14mm Male (R12 to R134a Converter)
MT0432	1/2" Acme to 1/4" Male (R134a Cylinder Adapter)
MT0433	1/4" Female to 1/2" Acme Male (Vacuum Pump)
MT1032	Anti blow back valve 1/2" Acme thread
MT1143	1/4" Female to M10 - 1.50 Male
MT1144	14mm Male to M12 x 1.75 Male
MT1145	14mm Male to M10 x 1.50 Male
MT1146	1/2" Acme Male to 1/8" Male NPT
MT1519	1/8" Male x 7/16"- 20 Male (With valve core)
MT1520	1/8" Male to 3/16"- 20 Male (With valve core)
MT1522	1/8" Male to 7/16"- 20 Male (With valve core)
MT1606	3/8"- 24 Male to M10 - 1.25 (With valve core)
MT1607	3/8"-24 Male to M12 - 1.50 (With valve core)

LEAK DETECTION DYES & SPRAY

UV Leak Detection
Fluorescing Dye



AR4280 (8 oz)



AR4285
(12 x 0.5 oz)

MT1062 Easy-fill Syringes



5505

For quick and easy leak
detection in pressurized tubes

- Anti Corrosive
- Non Irritating
- Non Flammable

MT1060

Dye Installation Hose
With Quick Connect



DYE & REFRIGERANT OIL INJECTOR

Part # AR6222



INTERNAL LIQUID IN-LINE FILTER



MT1579

In-Line Filter- OEM
Located internal of
liquid line
OEM: Located Liquid Line
Black - 60mm Length
GM: 89022560

Chevy /GMC Trucks- 07'-09'
Isuzu - 07'-09'

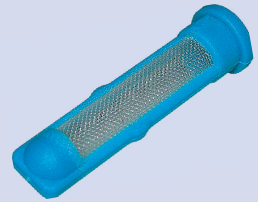

MT1580

In-Line Filter- OEM
Located internal of
liquid line
OEM: Located Liquid Line
Light Blue - 28mm Length
GM: 15951308

GM Cars - 08'
GM Trucks - 07'-08'
Saturn - 07'-08'



MT1581

In-Line Filter- OEM
Located internal of
liquid line
OEM: Located Liquid Line
Black - 60mm Length
with O-ring
GM: 25687579

GM Cars - 01'-03"

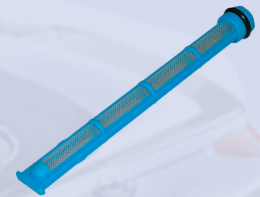

MT1582

In-Line Filter- OEM
Located internal of
liquid line
OEM: Located Liquid Line
Light Blue - 80mm Length
with O-ring GM: 10356437

GM Cars - 05'-09'



MT1583

In-Line Filter- OEM
Located internal of
liquid line
OEM: Located Liquid Line
Green - 80mm Length
with O-ring GM: 21999762

GM Cars - 06'-09'



MT1584

In-Line Filter- OEM
Located liquid line at
Expansion Valve
OEM: Located at
Expansion valve block
Light Blue - 28mm Length
Toyota: 88377-04010

Toyota - 05'- 08'

LEAK DETECTORS, ODS LOGS & INSTALLATION HOSES

AIR CONDITIONING SYSTEMS

SPRING LOCK RELEASE TOOLS

Part # 90001

Volkswagen Spring lock release tool

OEM approved tool easily opens spring lock connections during A/C service.



2 sizes to accommodate suction & discharge lines

Part # 90002

Mercedes Spring lock release tool



Specially designed to disconnect Mercedes spring lock connections

VULKAN LOKTRACER

LIKE NO OTHER LEAK DETECTOR!

Part # 5191

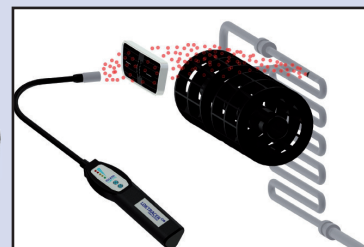

VULKAN Loktracer is an innovative tracer gas leak detection system.

All the advantages of existing leak detection methods – without the disadvantages of the conventional methods.

Using a gas mixture made up of 95% nitrogen and 5% hydrogen. The hydrogen share is used as the tracer gas. The LOKtracers react exclusively to hydrogen, which means there are no cross-sensitivities.

This means leak detection is extremely reliable. Hydrogen molecules are the smallest naturally occurring particles and escape from even the tiniest of leaks **(less than 1 g/year).**

This means the LOKtracer can also be used to trace very small leaks.

O.D.S CONTROL SERVICE LOGS

Part # AR4254

O-Zone Depleting Substance Emission Control Service Logs

Conforms to all Ontario Government O.D.S requirements

OZONE DEPLETING SUBSTANCE EMISSION CONTROL SERVICE LOG

NO REFRIGERANT TO BE ADDED UNTIL LEAK IS REPAIRED

DATE OF SERVICE: _____ WORK ORDER OR RECEIPT #: _____

NAME OF TECHNICIAN: _____ CERTIFICATE NUMBER: _____ EXPIRES: _____

LEAK REPAIR OR ODS RECHARGE (per manufacturer)	TEST RESULTS	REPAIR METHOD	CODE
LEAK DETECTED	YES	REPAIRED	1
LEAK DETECTED	NO	REPAIRED	2
DESCRIPTION OF WORK:			

Was this service performed as a sub-contract? YES NO

IF YES, please note of business you are acting agent for: _____

CODE: 1. NEW OR RECHARGE REFRIGERANT ADDED TO SYSTEM
2. RECHARGE REFRIGERANT ADDED TO SYSTEM
3. REFRIGERANT RECHARGE TO MANUFACTURER'S SPECIFICATION
4. REFRIGERANT RECHARGE FROM SYSTEM
5. REFRIGERANT RECHARGE FROM MANUFACTURER'S SPECIFICATION
6. REFRIGERANT RECHARGE FROM MANUFACTURER'S SPECIFICATION
7. SYSTEM NO LONGER CONTAINS REFRIGERANT

DATE OF SERVICE (DATE WHEN LEAK DETECTED OR WHEN LEAK WAS REPAIRED): _____

RECORD OF REFRIGERANT SERVICE
DO NOT REMOVE THIS RECORD FROM UNIT! FMS - 000111

REGISTRE DES TRAVAUX DE RÉCUPÉRATION D'ENTRETIEN ET DE DÉMANTÈLEMENT DES HALOCARBURES

Part # AR4261

Chaque ensemble de journaux d'entretien contient 25 formulaires en 3 parties, 25 pochettes protectrices et un stylo.

Approuvé au Québec

Registre des travaux de récupération, d'entretien et de démantèlement des halocarbures
Règlement sur les halocarbures (art. 59)

FMS - 000111

Climatisation de véhicule ou réfrigération de transport

1. Identification de l'intervenant

2. Type d'appareil (cochez la case appropriée)

3. Appareil de réfrigération de transport

4. Nature des travaux sur l'appareil

5. Halocarbure ajouté

6. Remarque

7. Signature

GAUGE SETS & INSTALLATION HOSES

Part # MT0399

R134a Gauge Set Complete with 72" Hoses and Couplers



Part # 0220

R134a Quick Coupler High & Low Side Kit With Shut off



Part # MT0405

Hose Extender Part # MT1456



R134a Replacement Hose 1/2" Acme Fitting

Part # MT0404

14mm x 1.5 1/2" Acme R134a Replacement Hose



Part # MT0403

High & Low Side Hose Extender Part # MT1417

14mm x 1.5 1/2" Acme R134a Replacement Hose



MT2151

R134a Repair Kit Used For 0220



AR4252



Installation Hose with Gauge

MT2173

R134a Charging Hose Replacement Gaskets & O-Rings



AR4233

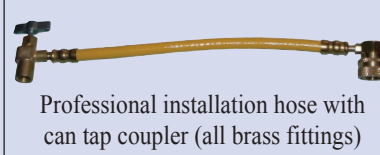

Professional installation hose with can tap coupler (all brass fittings)

CHEMICALS & LUBRICANT

PAG OILS (POLYALKYLENE GLYCOL)

(PAG Oil to Compressor application chart with ease)



PAG 46
Part # 49602
PAG 46 w/ UV Dye
Part # 50602

8oz



PAG 100
Part # 49603
PAG 100 w/ UV Dye
Part # 50603

8oz



PAG 150
Part # 49604
PAG 150 w/ UV Dye
Part # 50604

8oz

PAG OIL ASSORTMENTS

PAG Oil # 49605

Contains:

- (4) 49602
- (4) 49603
- (4) 49604

PAG Oil w/ UV Dye

50605 Contains:

- (4) 50602
- (4) 50603
- (4) 50604

ESTER OILS (POLYOLESTER)

Part # 49601 (1ea)



ESTER 100
w/ UV Dye

Case of (12)
Part # 49615

Part # 49597 (12pk)



ESTER 100

ESTER 100 w/ UV
dye Part # 51597

Part # 49620 (1ea)



2 oz ESTER 100
with UV Dye

VACUUM PUMP OIL

Part # 5098

Premium Vacuum
Pump Oil

937ml
Bottle



HYBRID ELECTRIC A/C LUBRICANT

Part # MT3032

Compatible with all Hybrid vehicles that utilize R134a A/C systems using electrically driven compressors, providing the ultimate in compressor protection. This hybrid electric A/C lubricant contains anti-wear agents and has maximum dielectric strength.

8oz
(237ml)



PRO PAO 68

Part # 49701

Universal Compressor Oil

Replaces PAG & Ester
Superior lubricant ensures
compressor longevity

NEW



32oz
Bottle

HYDROCARBON REFRIGERANT

Part # AR4247

NO LICENCE REQUIRED!

This formula was designed for A/C systems.
Compatible with R12 & R134a.

REPLA 134 is replacement that will reduce vent
temperatures and leak less than R12 or R134a

Part # AR4247M - 12 pack



PERFORMANCE SEALANTS

Metal Sealant

Part # AR4237
Kool Air Seal # 1



O-Ring & Hose Sealant

Part # AR4238
Kool Air Seal # 2



A/C FLUSH

Quick Dry Flush

Part # AR8201

Designed to clean and
remove contaminants
from R134a and R12
Automotive systems

Compatible with PAG,
Ester & Mineral Oils

AR8201-3 (3pk)
AR8201 (12pk)



EVAP CLEANER

Evaporator Treatment

Part # AR8202

Eliminates Most
offensive odors

Kills bacteria, mold &
mildew on evaporator
surfaces

AR8202-3 (3pk)
AR8202 (12pk)



FLUSH GUN

Part # AR6223

Condensers, Evaporators Hoses etc..



A/C SUPER FLUSH

Part # AR4202

Quick Dry Solvent
128oz Gallon



Complete Problem Solving Automotive Hardware

OIL DRAIN PLUG & GASKETS

0002B Drain plug gaskets  466 pieces	0303 Domestic OE Drain Plugs  66 pieces	0327 Oil Drain Plug & Gaskets  168 pieces	0354 Gaskets Metric  239 pieces	0355 Gaskets Metric  80 pieces	0440 '90-Present New Style  168 pieces
---	--	--	---	---	---

BRAKE LINE ASSORTMENTS

Wall Mount Rack

Empty Wall Racks

0084	3/16" & 1/4"
0091	12 Slot Wall Rack 5/16" & 3/8"
0100	28 Slot Metric Wall Rack
0101	25 Slot Wall Rack 3/16", 1/4", 5/16" & 3/8"



0010	3/16" Standard & Metric (Zinc)	43 pieces
0104	Japanese & European (PVF)	38 pieces
0105	Japanese (Zinc & Armored Zinc)	40 pieces
0111	3/16" & 1/4" (Cupro Nickel)	28 pieces
0280	3/16" & 1/4" (Zinc)	48 pieces
0297	5/16" & 3/8" (Zinc)	32 pieces
0298	3/16" & 1/4" (Armored Zinc)	31 pieces
0299	Japanese & Domestic (Zinc)	40 pieces
0343	Toyota/GM & Metric (Zinc)	32 pieces
0422	Standards, British, Japanese & Metric (Zinc)	308 pieces
0423	British, Japanese & Metric (Zinc)	140 pieces
0424	Standards 3/16", 1/4", 5/16" & 3/8" (Zinc)	94 pieces
0442	Metric, Japanese & Toyota/GM (Zinc)	74 pieces
0463	Standards 3/16" 1/4", 5/16" & 3/8" (Passivated Green)	62 pieces
0471	3/16" & 1/4" (Passivated Green)	46 pieces
0472	3/16" & 1/4" (Zinc)	70 pieces
0484	3/16" (Passivated Green)	32 pieces
0485	3/16" (Zinc)	32 pieces
0486	3/16" (Armored Zinc)	32 pieces
0488	Standards 3/16" 1/4", 5/16" & 3/8" (PVF)	66 pieces
0489	3/16" & 1/4" (Poly Vinyl Fluoride)	39 pieces
0493	Metric, Japanese, Toyota/GM & European (PVF)	74 pieces



Floor Stand Displays

Empty Floor Merchandiser
022-284

0015	3/16", 1/4", Japanese & European with Coils (Cupro Nickel)	177 pieces
0023	3/16", 1/4", Japanese & European (Cupro Nickel)	72 pieces
0391	Standards 3/16", 1/4", 5/16" & 3/8" (Zinc)	210 pieces
0392	Metric, British, Japanese & Domestic (Zinc)	140 pieces
0404	Standard 3/16", 1/4", 5/16" & 3/8" (Armored Zinc)	210 pieces
0420	Standard 3/16", 1/4", 5/16" & 3/8" (Zinc)	203 pieces
0421	3/16", 1/4", 5/16" & 3/8", Metric, Japanese, Euro & Domestic (Zinc)	310 pieces
0430	3/16", 1/4", Japanese & Domestic (Zinc)	210 pieces
0455	Metric, British, Japanese & European (Passivated Green)	126 pieces
0461	Standard 3/16", 1/4", 5/16" & 3/8" (Passivated Green)	210 pieces
0474	3/16", 1/4", Metric, Japanese & European (Passivated Green)	133 pieces
0487	British, Metric, Toyota, Japanese & Euro (Poly Vinyl Fluoride)	112 pieces
0490	3/16", 1/4", Metric, Japanese & European (Poly Vinyl Fluoride)	138 pieces
0491	Standard 3/16", 1/4", 5/16" & 3/8" (Poly Vinyl Fluoride)	125 pieces











Just Brake Lines (Lines ONLY)

0494	3/16" Standard Zinc (8" to 60") 5 each	35 pieces
0495	3/16" Standard Armored Zinc (8" to 60") 5 each	35 pieces
0496	Japanese Zinc (8" to 60") 5 each	35 pieces
0497	Metric Domestic Zinc (8" to 60") 5 each	35 pieces
0498	Japanese Armored Zinc (8" to 60") 5 each	35 pieces
0499	Metric Domestic Armored Zinc (8" to 60") 5 each	35 pieces

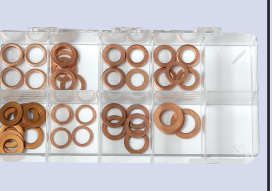

BRAKE LINE FITTING & BLEEDER SCREW ASSORTMENTS







0014 Brake Line Fittings  91 pieces	0020 Tube Nuts, Adapters & Coil  CN3 Included 105 pieces	0021 Tube Nuts, Adapters & Coils  CN3 & CN4 Included 155 pieces	0072 Bleeder Screws & Clips  157 pieces	0107 Adapters & Unions  45 pieces
0108 Flex Line Bolts & Gaskets  21 pieces	0231 Copper Flex Line Gaskets  48 pieces	0251 Complete Brake Line Tube Nut & Unions  176 pieces		0252 Brake Adapters & Tees  40 pieces

ASSORTMENTS

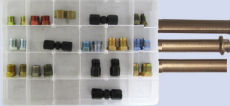









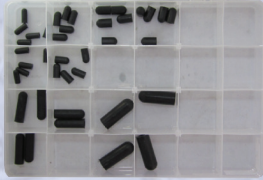

BRAKE LINE FITTING & BLEEDER SCREW ASSORTMENTS

<p>0269 Brake Line Fittings</p>  <p>158 pieces</p>	<p>0273 Brake Line Adapters</p>  <p>24 pieces</p>	<p>0310 Brake Line Tube Nuts</p>  <p>55 pieces</p>	<p>0311 Metric Tube Nuts, Adapters & Unions</p>  <p>60 pieces</p>	<p>0314 Standard & Metric Tube Nuts & Unions</p>  <p>55 pieces</p>
<p>0349 6mm Brake Line Fittings</p>  <p>16 pieces</p>	<p>0373 Brake Line Adapters</p>  <p>7 pieces</p>	<p>0475 Bleeder Screws & Caps</p>  <p>144 pieces</p>	<p>0477 Tubing Retainer Clips</p>  <p>144 pieces</p>	

TRANSMISSION & POWER STEERING ASSORTMENTS

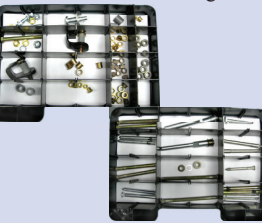
<p>0128 Power Steering Rack Line Repair</p>  <p>Includes (7) 30" Repair lines with flares 40 pieces</p>	<p>0320 Fittings & Quick Connects</p>  <p>45 pieces</p>	<p>0390 Retainer Clips</p>  <p>44 pieces</p>	<p>0438 Tube Nuts</p>  <p>35 pieces</p>	<p>0439 Quick Connects & Fittings</p>  <p>23 pieces</p>	<p>0462 Repair Lines</p>  <p>20 pieces</p>
---	--	---	--	--	---

GENERAL HARDWARE ASSORTMENTS

<p>0037 E-Clips</p>  <p>120 pieces</p>	<p>0216 Vacuum Caps</p>  <p>40 pieces</p>	<p>0255 Door Trim Panel Clips</p>  <p>62 pieces</p>	<p>0263 Standard O-Rings</p>  <p>225 pieces</p>	<p>0264 Metric O-Rings</p>  <p>225 pieces</p>
<p>0282 Vacuum Connectors</p>  <p>105 pieces</p>	<p>0300 360° Seal Clamps</p>  <p>105 pieces</p>	<p>0351 Hose Menders</p>  <p>28 pieces</p>	<p>0364 Cabin Air Filter Hardware</p>  <p>79 pieces</p>	<p>0381 Hood Prop Rod Retainer Clips</p>  <p>41 pieces</p>
<p>0393 Door Pins & Bushings</p>  <p>99 pieces</p>	<p>0428 Metric Grease Fittings</p>  <p>100 pieces</p>	<p>0429 Fractional Grease Fittings</p>  <p>100 pieces</p>	<p>0433 Licence Plate Hardware</p>  <p>146 pieces</p>	<p>0492 Splash Panel Clips</p>  <p>146 pieces</p>

For Complete Bill of Materials of Assortments visit us at www.fmsiinc.com or call 1-800-651-7445

ASSORTMENTS

PLASTIC & METAL ASSORTMENT TRAYS & RACKS

- 0066 24 Hole Plastic Box
- 0070 Double Sided Plastic Box
- 0071 6 Hole Plastic Box (Small)
- 0073 6 Hole Plastic Box (Large)
- 0074 12 Hole Plastic Box (Large)
- 0075 18 Hole Plastic Box (Large)
- 0076 12 Hole Plastic Box (Small)
- 0077 18 Hole Plastic Box (Small)
- 0078 10 Hole Plastic Box
- 0087 24 Hole Metal Tray
- 0088 4 Drawer Metal Rack
- 0089 32 Hole Metal Tray

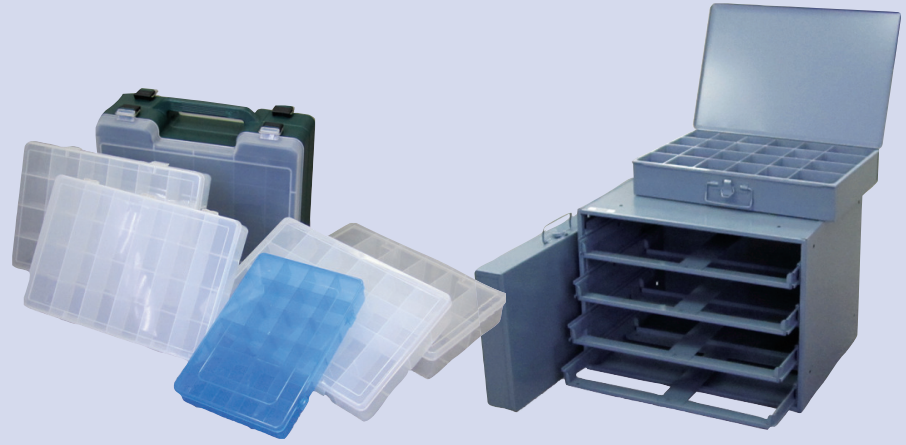







AIR CONDITIONING ASSORTMENTS

ASSORTMENTS



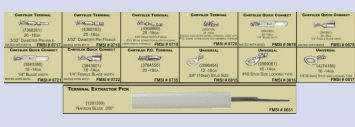

<p>0117 A/C Line Splice & Block Off</p> <p>21 pieces</p>	<p>0218 72" Hose Set with Shut-offs</p> <p>5 pieces</p>	<p>0219 72" Hose Set</p> <p>3 pieces</p>	<p>0220 R134a High & Low Side Couplers</p> <p>2 pieces</p>
<p>0324 A/C Valve Cores</p> <p>29 pieces</p>	<p>0325 Orifice Tubes</p> <p>25 pieces</p>	<p>0336 A/C O-Rings</p> <p>140 pieces</p>	<p>0340 Chrysler A/C Metal Gaskets</p> <p>52 pieces</p>
<p>0344 R134a O-Rings</p> <p>80 pieces</p>	<p>0375 GM Sealing Washers</p> <p>57 pieces</p>	<p>0378 R134a Ports</p> <p>10 pieces</p>	<p>0379M A/C Line Splice</p> <p>19 pieces</p> <p><i>Now Sub To 0379M</i></p>
<p>0379M Master A/C Tube Joiners & Block offs</p> <p>35 pieces</p>	<p>0400 GM A/C O-Ring</p> <p>210 pieces</p>	<p>0401 Ford A/C O-Ring</p> <p>216 pieces</p>	<p>0402 Chrysler A/C O-Ring</p> <p>216 pieces</p>
<p>0403 Import A/C O-Ring</p> <p>120 pieces</p>	<p>0414 A/C Tube End Repair</p> <p>21 pieces</p>	<p>0445 GM Sealing Washers</p> <p>43 pieces</p>	<p>0446 Orifice Tubes, & Service Ports</p> <p>36 pieces</p>
<p>0464 Lok Crimp Hose System</p> <p>13 pieces</p>	<p>0466 Master Rapid Seal Kits</p> <p>Domestic, Imports & Trucks 33 pieces</p>	<p>0480 A/C Service Port Caps</p> <p>50 pieces</p>	<p>0481 Valve Cores & Service Port Caps</p> <p>50 pieces</p>

For Complete Bill of Materials of Assortments visit us at www.fmsiinc.com or call 1-800-651-7445

ELECTRICAL TERMINALS

<p>0205 OEM Terminals</p>  <p>121 pieces</p>	<p>0352 Solderless Terminals</p>  <p>230 pieces</p>	<p>0382 Heat Shrink Solderless Terminals</p>  <p>132 pieces</p>	<p>0383 GM Weather Pack Terminals</p>  <p>102 pieces</p>
<p>0384 GM Micro Pack Terminals</p>  <p>134 pieces</p>	<p>0385 GM Metri Pack Terminals</p>  <p>95 pieces</p>	<p>0386 Ford Mini Terminals</p>  <p>95 pieces</p>	<p>0387 Chrysler Pin, Blade & PC Terminals</p>  <p>73 pieces</p>

BRASS FITTINGS & HARDWARE

<p>0018 Brass Adapters, Unions & Tees</p>  <p>45 pieces</p>	<p>0107 Brass Adapters & Unions</p>  <p>45 pieces</p>
<p>0252 Brake Line Adapter & Tees</p>  <p>40 pieces</p>	<p>0437 Brass Compression Unions</p>  <p>31 pieces</p>







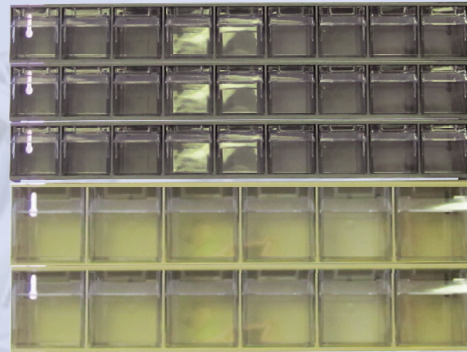









0130

PART STORE BRASS ASSORTMENT



FUEL LINE & FITTING ASSORTMENTS

<p>0103 Fuel Line Tube Nuts</p>  <p>47 pieces</p>	<p>0200 Fuel Line Update Kit</p>  <p>18 pieces</p>	<p>0283 Sending Unit Repair Lines</p>  <p>30 pieces</p>	<p>0289 Fuel Line Retainer Clips</p>  <p>31 pieces</p>	<p>0300 360° Seal Clamps</p>  <p>96 pieces</p>
<p>0301 Nylon Fuel Line Hardware</p>  <p>122 pieces</p>	<p>0304 Steel to Nylon Adapters</p>  <p>74 pieces</p>	<p>0329 Fuel Injection Clamps</p>  <p>36 pieces</p>	<p>0348 Fuel Line Retainer Clips</p>  <p>52 pieces</p>	<p>0365 Fuel Line Repair Center</p>  <p>192 pieces</p> <p>0365S- Fuel Line Repair Center No Rack</p>
<p>0380 Nylon Fuel Line Quick Connects</p>  <p>38 pieces</p>	<p>0388 Nylon Fuel Line Quick Connects</p>  <p>47 pieces</p>	<p>0434 Quick Lube Fuel Repair</p>  <p>53 pieces</p>	<p>0454M Master Fuel Line Repair & Replace</p>  <p>Installs All Connectors Including Larger Evaporator Style</p> <p>Watch the video at fmsiinc.com</p> <p>90 pieces</p>	

For Complete Bill of Materials of Assortments visit us at www.fmsiinc.com or call 1-800-651-7445

ASSORTMENTS

MINI VANS, SUV'S & TRUCKS REAR A/C LINE REPLACEMENT KITS

NO DEALER LINES REQUIRED!

NEW

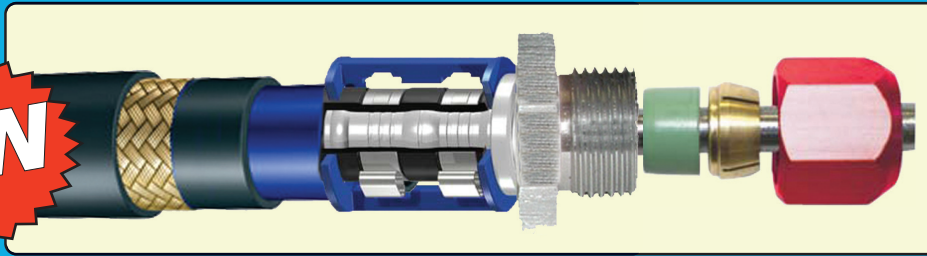

NO HOSE CRIMPER
TO ATTACH REDUCED BARRIER HOSE

NO SPECIAL TOOLS
TO ATTACH TO EXISTING ALUMINUM TUBING

EACH KIT INCLUDES 12' REDUCED BARRIER HOSE AND ATTACHING HARDWARE FOR REAR A/C LINE REPLACEMENT.



12' REDUCED BARRIER HOSE



HOSE FITTINGS FOR ALUMINUM TUBE REPLACEMENT.

Kit No.	Description
5605	5/16" Rear A/C Line Replacement
5606	3/8" Rear A/C Line Replacement
5607	1/2" Rear A/C Line Replacement
5608	5/8" Rear A/C Line Replacement
5609	3/4" Rear A/C Line Replacement

FITTINGS TO BE USED WITH AIR CONDITIONING REDUCED BARRIER HOSE ONLY

GM 2500 & 3500 SERIES DIESEL FUEL COOLER REPAIR LINE

PART # 3158

NEW

EASY TO INSTALL REPAIR LINE



GENERAL MOTORS 2001 TO 2011
2500 & 3500 SERIES DIESEL PICK UP TRUCKS

INSTALLATION INSTRUCTIONS

- 1) Unscrew leaking diesel fuel line from cooler.
- 2) Thread pipe thread adapter end of repair line into cooler.
- 3) Cut existing cooler line beyond flex section collar crimp at a solid section of steel tube running along the frame rail (Maximum 24" length from cooler).
- 4) Clean tube at compression fitting join with scuff pad provided.
- 5) Shorten repair line length if necessary and use 90° or straight compression union (included) to complete connection.