



FMSI EDELMANN FITTINGS

PROBLEM SOLVING AUTOMOTIVE HARDWARE





The Official Guide Book
TUBE NUTS **V2**





FMSI EDELMANN FITTINGS

THE OFFICIAL TUBE NUT GUIDE
STANDARD INVERT FLARE & SHORT FEMALE TUBE NUTS





STANDARD INVERT FLARE TUBE NUTS

Part # 3597	121002	Part # 3000	121003	Part # 3001	121030	Part # 3441	-
	Tube: 1/8" Thread: 5/16" - 28 Hex: 5/16" Length: 0.52" Seat: Invert		Tube: 3/16" Thread: 3/8" - 24 Hex: 3/8" Length: 0.58" Seat: Invert		Tube: 3/16" Thread: 3/8" - 24 Hex: 3/8" Length: 0.82" Seat: Invert Style: Long		Tube: 3/16" Thread: 3/8" - 24 Hex: 9/16" Length: 0.58" Seat: Invert
		BLF-12		BLF-10			

STANDARD INVERT FLARE TUBE NUTS





Part # 3424	-	Part # 3003	121004	Part # 3004	121040	Part # 3415	-
	Tube: 3/16" Thread: 3/8" - 24 Hex: 7/16" Length: 0.58" Seat: Invert		Tube: 1/4" Thread: 7/16" - 24 Hex: 7/16" Length: 0.57" Seat: Invert		Tube: 1/4" Thread: 7/16" - 24 Hex: 7/16" Length: 0.82" Seat: Invert Style: Long		Tube: 1/4" Thread: 7/16" - 24 Hex: 9/16" Length: 0.58" Seat: Invert
		BLF-13		BLF-16			

STANDARD INVERT FLARE TUBE NUTS

Part # 6843		Part # 3006	121005	Part # 3015	121006	Part # 3442	-
	Tube: 1/4" Thread: 7/16" - 20 Hex: 1/2" Length: 20.9mm Seat: Invert		Tube: 5/16" Thread: 1/2" - 20 Hex: 1/2" Length: 0.63" Seat: Invert		Tube: 3/8" Thread: 5/8" - 18 Hex: 5/8" Length: 0.67" Seat: Invert		Tube: 3/8" Thread: 5/8" - 18 Hex: 5/8" Length: 0.79" Seat: Invert Style: Long
		BLF-14		BLF-15		PSR-013	

STANDARD INVERT FLARE TUBE NUTS

STEEL INVERT FLARE

Part # 3016	-	Part # 6814		Part # 3399	-	Part # 3489	-
	Tube: 1/2" Thread: 3/4" - 18 Hex: 3/4" Length: 0.74" Seat: Invert		Tube: 3/8" Thread: 11/16" - 18 Hex: 11/16" Length: 0.695" Seat: Invert		Tube: 7/16" Thread: 11/16" - 18 Hex: 11/16" Length: 0.67" Seat: Invert		Tube: 5/16" Thread: 1/2" - 20 Hex: 5/8" Length: 0.56" Seat: Invert





FMSI EDELMANN FITTINGS

THE OFFICIAL TUBE NUT GUIDE
SHORT FEMALE INVERT FLARE & METRIC INVERT FLARE







STEEL INVERT FLARE

STANDARD OVERSIZED INVERT FLARE TUBE NUTS





Part # 6808	Part # 3022 121034	Part # 6841	Part # 3023 121072
 <p>Tube: 3/8" Thread: 5/8" - 18 Hex: 5/8" Length: 0.50" Seat: Invert</p>	<p>RED</p>  <p>Tube: 3/16" Thread: 7/16" - 24 Hex: 7/16" Length: 0.57" Seat: Invert Style: Oversized</p> <p>BLF-11</p>	 <p>Tube: 3/16" Thread: 7/16" - 20 Hex: 7/16" (11mm) Length: 22.5mm Seat: Invert</p>	<p>GREEN</p>  <p>Tube: 3/16" Thread: 1/2" - 20 Hex: 9/16" Length: 0.62" Seat: Invert Style: Oversized</p> <p>BLF-41</p>

STANDARD OVERSIZED INVERT FLARE TUBE NUTS





Part # 3024 121039	Part # 3025 121049	Part # 3026 121045	Part # 3439
<p>OLIVE</p>  <p>Tube: 3/16" Thread: 9/16" - 18 Hex: 5/8" Length: 0.66" Seat: Invert Style: Oversized</p> <p>BLF-42</p>	<p>BLUE</p>  <p>Tube: 1/4" Thread: 9/16" - 18 Hex: 9/16" Length: 0.62" Seat: Invert Style: Oversized</p> <p>BLF-43</p>	<p>YELLOW ZINC</p>  <p>Tube: 1/4" Thread: 1/2" - 20 Hex: 1/2" Length: 0.63" Seat: Invert Style: Oversized</p> <p>BLF-44</p>	<p>BLACK</p>  <p>Tube: 3/16" Thread: 1/2" - 20 Hex: 1/2" Length: 0.62" Seat: Invert Style: Oversized</p>

STANDARD OVERSIZED INVERT FLARE TUBE NUTS

METRIC INVERT FLARE TUBE NUTS

Part # 3462 121082	Part # 3494 -	Part # 6810 -	Part # 6811 -
<p>WHITE ZINC SILVER</p>  <p>Tube: 1/4" Thread: 9/16" - 18 Hex: 5/8" Length: 0.78" Seat: Invert Style: Oversized</p>	<p>BLACK</p>  <p>Tube: 3/16" Thread: 1/2" - 20 Hex: 9/16" Length: 0.75" Seat: Invert Style: Oversized</p>	<p>BLACK</p>  <p>Tube: 3/16" Thread: 9/16" - 20 Hex: 9/16" Length: 0.758" Seat: Invert Style: Oversized Lg</p>	 <p>Tube: 3/16" Thread: M9 - 1.25 Hex: M10 Length: 20.2mm Seat: Invert</p>

METRIC INVERT FLARE TUBE NUTS

Part # 3043 121071	Part # 3417 121050	Part # 3409 -	Part # 3407 121074
 <p>Tube: 3/16" Thread: M10 - 1.0 Hex: M10 Length: 16.3mm Seat: Invert Style: Japanese</p>	 <p>Tube: 3/16" Thread: M10 - 1.0 Hex: 7/16" Length: 20mm Seat: Invert Style: Toyota/GM L</p>	 <p>Tube: 3/16" Thread: M11 - 1.5 Hex: M12 Length: 17.6mm Seat: Invert Style: Dom/Japanese</p>	 <p>Tube: 3/16" Thread: M12 - 1.0 Hex: M14 Length: 17.7mm Seat: Invert Style: Dom/Japanese</p>



FMSI EDELMANN FITTINGS

THE OFFICIAL TUBE NUT GUIDE

STANDARD OVERSIZE, METRIC INVERT FLARE & METRIC STAINLESS STEEL, INVERT FLARE

METRIC INVERT FLARE TUBE NUTS

Part # 6840	Part # 6813	Part # 6812	Part # 6800
-	121068	-	-
			
Tube: 1/4" Thread: M11 - 1.0 Hex: M12 Length: 17.8mm Seat: Invert	Tube: 1/4" Thread: M12 - 1.0 Hex: M14 Length: 20.5mm Seat: Invert	Tube: 1/4" Thread: M12 - 1.5 Hex: M13 Length: 20.5mm Seat: Invert	Tube: 5/16" Thread: M13 - 1.5 Hex: M14 Length: 15.5mm Seat: Invert



METRIC INVERT FLARE TUBE NUTS

STAINLESS STEEL INVERT FLARE TUBE NUTS



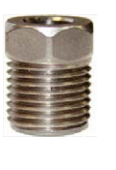

Part # 6803		Part # 3000SS	Part # 3001SS
-	-	-	-
			
Tube: 5/16" Thread: M14 - 1.5 Hex: M14 Length: 25mm Seat: Invert		Tube: 3/16" Thread: 3/8" - 24 Hex: 3/8" Length: 0.57" Seat: Invert	Tube: 3/16" Thread: 3/8" - 24 Hex: 3/8" Length: 0.81" Seat: Invert Style: Long
		BLSF-12	BLSF-10

STAINLESS STEEL INVERT FLARE TUBE NUTS

OVERSIZED STAINLESS STEEL INVERT FLARE TUBE NUTS

Part # 3003SS	Part # 3004SS	Part # 3006SS	Part # 3015SS
-	-	-	-
			
Tube: 1/4" Thread: 7/16" - 24 Hex: 7/16" Length: 0.57" Seat: Invert	Tube: 1/4" Thread: 7/16" - 24 Hex: 7/16" Length: 0.81" Seat: Invert Style: Long	Tube: 5/16" Thread: 1/2" - 20 Hex: 1/2" Length: 0.62" Seat: Invert	Tube: 3/8" Thread: 5/8" - 18 Hex: 9/16" Length: 0.67" Seat: Invert
BLSF-13	BLSF-16	BLSF-14	BLSF-15

OVERSIZED STAINLESS STEEL INVERT FLARE TUBE NUTS

Part # 3022SS	Part # 3023SS	Part # 3024SS	Part # 6810SS
-	-	-	-
			
Tube: 3/16" Thread: 7/16" - 24 Hex: 7/16" Length: 0.57" Seat: Invert Style: Oversized	Tube: 3/16" Thread: 1/2" - 20 Hex: 9/16" Length: 0.60" Seat: Invert Style: Oversized	Tube: 3/16" Thread: 9/16" - 18 Hex: 5/8" Length: 0.62" Seat: Invert Style: Oversized	Tube: 3/16" Thread: 9/16" - 20 Hex: 9/16" Length: 0.76" Seat: Invert Style: Oversized
BLSF-11	BLSF-41	BLSF-42	

FMSI EDELMANN FITTINGS

THE OFFICIAL TUBE NUT GUIDE





METRIC STAINLESS STEEL, INVERT/BUBBLE FLARE & BLOCK OFF TUBE NUTS & PLUGS



OVERSIZED STAINLESS STEEL INVERT FLARE TUBE NUTS

3/16" X 10MM METRIC STAINLESS STEEL

3/16" TUBE METRIC STAINLESS STEEL





Part #	Part #	Part #	Part #
3025SS	3026SS	3043SS	3028SS
			
Tube: 1/4" Thread: 9/16" - 18 Hex: 9/16" Length: 0.65" Seat: Invert Style: Oversized	Tube: 1/4" Thread: 1/2" - 20 Hex: 1/2" Length: 0.62" Seat: Invert Style: Oversized	Tube: 3/16" Thread: M10 - 1.0 Hex: M10 Length: 16mm Seat: Invert Style: Japanese	Tube: 3/16" Thread: M10 - 1.0 Hex: M12 Length: 17mm Seat: Bubble/ISO Style: Euro/Domestic
BLSF-43	BLSF-44	BLSF-40	BLSF-39

3/16" TUBE METRIC STAINLESS STEEL

3/16" TUBE BRITISH THREAD

3/16" TUBE US THREAD

1/4" TUBE US THREAD

Part #	Part #	Part #	Part #
3041SS	3410	6842	6844
			
Tube: 3/16" Thread: M12 - 1.0 Hex: M13 Length: 18.1mm Seat: Bubble/ISO Style: Long	Tube: 3/16" Thread: 3/8" - 24 Hex: 7/16" Length: 0.83" Seat: Bubble/ISO Style: British/US Thread	Tube: 3/16" Thread: 7/16" - 20 Hex: 13mm Length: 21mm Seat: Bubble/ISO	Tube: 1/4" Thread: 7/16" - 20 Hex: 13mm Length: 19.25mm Seat: Bubble/ISO
BLSF-48	BLF-38		

3/16" TUBE METRIC BUBBLE/ISO FLARE TUBE NUTS 10MM - 1.0

Part #	Part #	Part #	Part #
3028	3411	3414	3420
			
Tube: 3/16" Thread: M10 - 1.0 Hex: M12 Length: 18mm Seat: Bubble/ISO Style: Euro/Domestic	Tube: 3/16" Thread: M10 - 1.0 Hex: M11 Length: 20mm Seat: Bubble/ISO Style: Long	Tube: 3/16" Thread: M10 - 1.0 Hex: M11 Length: 20.2mm Seat: Bubble/ISO Style: VW/Audi	Tube: 3/16" Thread: M10 - 1.0 Hex: M13 Length: 19mm Seat: Bubble/ISO Style: Ford/Imports
BLF-39			

3/16" TUBE METRIC INVERT 10MM - 1.0

3/16" TUBE METRIC BUBBLE 10MM - 1.0

3/16" TUBE METRIC BUBBLE/ISO 10MM - 1.25

3/16" TUBE METRIC BUBBLE/ISO 10MM - 1.50

Part #	Part #	Part #	Part #
3449	3463	3470	3492
			
Tube: 3/16" Thread: M10 - 1.0 Hex: M10 Length: 18.2mm Seat: Invert Style: OE Toyota	Tube: 3/16" Thread: M10 - 1.0 Hex: M11 Length: 25.3mm Seat: Bubble/ISO Style: Euro/Domestic	Tube: 3/16" Thread: M10 - 1.25 Hex: M11 Length: 20.2mm Seat: Bubble/ISO Style: Euro/Domestic	Tube: 3/16" Thread: M10 - 1.50 Hex: M11 Length: 20mm Seat: Bubble/ISO Style: Euro/Domestic



FMSI EDELMANN FITTINGS

THE OFFICIAL TUBE NUT GUIDE

BUBBLE FLARE & BLOCK OFF TUBE NUTS & PLUGS

3/16" TUBE METRIC BUBBLE/ISO 11MM - 1.0

3/16" TUBE METRIC BUBBLE/ISO 11MM - 1.5

3/16" TUBE METRIC BUBBLE/ISO 12MM - 1.0

3/16" TUBE METRIC BUBBLE/ISO 12MM - 1.0

Part #	BUBBLE/ISO	Part #	BUBBLE/ISO	Part #	BUBBLE/ISO	Part #	BUBBLE/ISO
3477	121073	3040	276011	3041	276012	3493	-
	Tube: 3/16" Thread: M11 - 1.0 Hex: M11 Length: 17.5mm Seat: Bubble/ISO Style: Euro/Domestic		Tube: 3/16" Thread: M11 - 1.5 Hex: M12 Length: 17.7mm Seat: Bubble/ISO Style: Domestic		Tube: 3/16" Thread: M12 - 1.0 Hex: M14 Length: 17.8mm Seat: Bubble/ISO Style: Domestic		Tube: 3/16" Thread: M12 - 1.0 Hex: M13 Length: 19.5mm Seat: Bubble/ISO Style: Long

3/16" TUBE METRIC BUBBLE/ISO 12MM - 1.25

3/16" TUBE BUBBLE/ISO M13 - 1.5

M6 TUBE BUBBLE/ISO M12 - 1.0

M6 TUBE BUBBLE/ISO M12 - 1.5

Part #	BUBBLE/ISO	Part #	BUBBLE/ISO	Part #	BUBBLE/ISO	Part #	BUBBLE/ISO
3426	-	3042	276013	3421	-	3422	-
	Tube: 3/16" Thread: M12 - 1.25 Hex: M14 Length: 17.8mm Seat: Bubble/ISO Style: Euro/Domestic		Tube: 3/16" Thread: M13 - 1.5 Hex: M14 Length: 18.3mm Seat: Bubble/ISO Style: Domestic		Tube: M6 Thread: M12 - 1.0 Hex: M14 Length: 20.5mm Seat: Bubble/ISO Style: Euro/Dom		Tube: M6 Thread: M12 - 1.5 Hex: M14 Length: 20.5mm Seat: Bubble/ISO Style: Euro/Dom

M6 TUBE BUBBLE/ISO M14 - 1.5

1/4" TUBE BUBBLE/ISO M11 - 1.0

1/4" TUBE BUBBLE/ISO M12 - 1.0

Part #	BUBBLE/ISO	Part #	BUBBLE/ISO	Part #	BUBBLE/ISO	Part #	BUBBLE/ISO
3423	-	3490	-	3413	121074	3496	-
	Tube: M6 Thread: M14 - 1.5 Hex: M15 Length: 21mm Seat: Bubble/ISO Style: Euro/Dom		Tube: 1/4" Thread: M11 - 1.0 Hex: M12 Length: 17.8mm Seat: Bubble/ISO Style: Euro/Domestic		Tube: 1/4" Thread: M12 - 1.0 Hex: M13 Length: 20.5mm Seat: Bubble/ISO Style: Ford/Imports		Tube: 1/4" Thread: M12 - 1.0 Hex: M13 Length: 20.3mm Seat: Bubble/ISO Style: Short Dog Pt

1/4" TUBE BUBBLE/ISO M12 - 1.25

1/4" TUBE BUBBLE/ISO M12 - 1.5

1/4" TUBE BUBBLE/ISO M12 - 1.75

1/4" TUBE BUBBLE/ISO M13 - 1.5

Part #	BUBBLE/ISO	Part #	BUBBLE/ISO	Part #	BUBBLE/ISO	Part #	BUBBLE/ISO
3433	-	3495	-	3447	-	3408	-
	Tube: 1/4" Thread: M12 - 1.25 Hex: M12 Length: 20mm Seat: Bubble/ISO Style: Euro/Domestic		Tube: 1/4" Thread: M12 - 1.5 Hex: M13 Length: 20.3mm Seat: Bubble/ISO Style: Euro/Domestic		Tube: 1/4" Thread: M12 - 1.75 Hex: M13 Length: 26.2mm Seat: Bubble/ISO Style: Euro/Domestic		Tube: 1/4" Thread: M13 - 1.5 Hex: M14 Length: 18.3mm Seat: Bubble/ISO Style: Euro/Domestic





FMSI EDELMANN FITTINGS

THE OFFICIAL TUBE NUT GUIDE





METRIC INVERT/BUBBLE FLARE & BLOCK OFF TUBE PLUGS/POWER STEERING & TRANSMISSION FUEL LINE NUTS







1/4" TUBE BUBBLE/ISO M14 - 1.5 5/16" TUBE BUBBLE/ISO M14 - 1.5 5/16"/8MM TUBE 5/8" - 18 5/16"/8MM TUBE 14MM - 1.25

Part #	BUBBLE/ISO	Part #	BUBBLE/ISO	Part #	O-RING	Part #	INVERT
6801		6802	109400	3443	-	3448	-
	Tube: 1/4" Thread: M14 - 1.5 Hex: M15 Length: 21mm Seat: Bubble/ISO		Tube: 5/16" Thread: M14 - 1.5 Hex: M15 Length: 18.5mm Seat: Bubble/ISO		Tube: 5/16" / 8mm Thread: 5/8" - 18 Hex: 5/8" Length: 0.664" Seat: O-Ring		Tube: 5/16" / 8mm Thread: 14mm - 1.25 Hex: 14mm Length: 22.5mm Seat: Invert





5/16"/8MM TUBE 14MM - 1.5 5/16"/8MM TUBE 14MM - 1.5 5/16"/8MM TUBE 14MM - 1.5

Part #	O-RING	Part #	INVERT	Part #	INVERT	Part #	BUBBLE/ISO
3009	-	3445	-	3487	-	3488	-
							
FLR-009		Tube: 5/16" / 8mm Thread: M14 - 1.5 Hex: M16 Length: 18.6mm Seat: O-Ring	Tube: 5/16" / 8mm Thread: 14mm - 1.5 Hex: 14mm Length: 20.3mm Seat: Invert	Tube: 5/16" / 8mm Thread: 14mm - 1.5 Hex: 14mm Length: 28.1mm Seat: Invert		Tube: 5/16" / 8mm Thread: 14mm - 1.5 Hex: 14mm Length: 28mm Seat: Bubble/ISO	

5/16" TUBE 1/2" - 20 3/8" TUBE 16MM - 1.5 3/8" TUBE 16MM - 1.5 3/8" TUBE 16MM - 1.5

Part #	INVERT	Part #	O-RING	Part #	INVERT	Part #	O-RING
6805	-	3008	-	3434	-	3435	-
							
Cooler/Power Steering		FLR-008		PSR-016			
Tube: 5/16" Thread: 1/2" - 20 Hex: 16mm Length: 1.00" Seat: Invert		Tube: 3/8" Thread: M16 - 1.5 Hex: M16 Length: 19.20mm Seat: O-Ring		Tube: 3/8" Thread: 16mm - 1.5 Hex: 16mm Length: 0.673" Seat: Invert		Tube: 3/8" Thread: M16 - 1.50 Hex: M18 Length: 21.5mm Seat: O-Ring	

3/8" TUBE 16MM - 1.5 3/8" TUBE 18MM - 1.5 3/8" TUBE 18MM - 1.5 3/8" TUBE 16MM - 1.5

Part #	O-RING	Part #	O-RING	Part #	O-RING	Part #	O-RING
3464	-	3436	-	3438	-	6806	-
							
PSR-018				PSR-017			
Tube: 3/8" Thread: M16 - 1.50 Hex: M16 Length: 29.8mm Seat: O-Ring		Tube: 3/8" Thread: M18 - 1.50 Hex: M18 Length: 20.4mm Seat: O-Ring		Tube: 3/8" Thread: M18 - 1.50 Hex: M18 Length: 21.4mm Seat: O-Ring		Tube: 3/8" Thread: M16 - 1.50 Hex: M18 Length: 16.5mm Seat: O-Ring	



FMSI EDELMANN FITTINGS

THE OFFICIAL TUBE NUT GUIDE





POWER STEERING & TRANSMISSION FUEL LINE NUTS

3/8" TUBE 18MM - 1.5

3/8" TUBE 18MM - 1.5

3/16" BLOCK OFF TUBE PLUGS

1/4" BLOCK OFF TUBE PLUGS





Part #	O-RING	Part #	INVERT	Part #	INVERT	Part #	INVERT
6807	-	6850	-	6829	120300	6830	120400
	Tube: 3/8" Thread: M18 - 1.50 Hex: M18 Length: 20.5mm Seat: O-Ring		Tube: 3/8" Thread: 5/8" - 18 Hex: 5/8"/16mm Length: 26.9mm Seat: Invert Ford Cooler Lines		Tube: 3/16" Thread: 3/8" - 24 Hex: 3/8" Length: 0.525" Seat: Invert 42° Style: Plug BLF-60		Tube: 1/4" Thread: 7/16" - 24 Hex: 7/16" Length: 0.55" Seat: Invert 42° Style: Plug

3/16" TUBE PLUG 9/16" - 18

3/16" TUBE PLUG 1/2" - 20

1/4" TUBE PLUG 9/16" - 18





1/4" TUBE PLUG 1/2" - 20

Part #	INVERT	Part #	INVERT	Part #	INVERT	Part #	INVERT
6815	-	6816	-	6817	-	6818	-
OLIVE 	Tube: 3/16" Thread: 9/16" - 18 Hex: 5/8" Length: 0.66" Seat: Invert 42° Style: Steel Plug	GREEN 	Tube: 3/16" Thread: 1/2" - 20 Hex: 9/16" Length: 0.62" Seat: Invert 42° Style: Steel Plug	BLUE 	Tube: 1/4" Thread: 9/16" - 18 Hex: 9/16" Length: 0.62" Seat: Invert 42° Style: Steel Plug	GOLD 	Tube: 1/4" Thread: 1/2" - 20 Hex: 1/2" Length: 0.63" Seat: Invert 42° Style: Steel Plug

5/16" BLOCK OFF TUBE PLUGS



3/8" BLOCK OFF TUBE PLUGS

3/16" BLOCK OFF TUBE PLUGS 10MM - 1.0

Part #	INVERT	Part #	INVERT	Part #	INVERT	Part #	BUBBLE/ISO
6831	-	6832	-	6825	-	6826	-
	Tube: 5/16" Thread: 1/2" - 20 Hex: 1/2" Length: 0.620" Seat: Invert 42° Style: Plug		Tube: 3/8" Thread: 5/8" - 18 Hex: 5/8" Length: 0.650" Seat: Invert 42° Style: Plug		Tube: 3/16" Thread: M10 - 1.0 Hex: M10 Length: 18mm Seat: Invert Style: Plug		Tube: 3/16" Thread: M10 - 1.0 Hex: M10 Length: 18mm Seat: Bubble/ISO Style: Plug

3/16" BLOCK OFF TUBE PLUGS 12MM - 1.0

INTRODUCTION TO BRASS

Part #	INVERT	Part #	BUBBLE/ISO
6827	-	6828	-
	Tube: 3/16" Thread: M12 - 1.0 Hex: M12 Length: 21mm Seat: Invert Style: Plug		Tube: 3/16" Thread: M12 - 1.0 Hex: M13 Length: 20.7mm Seat: Bubble/ISO Style: Plug

"Seal with Precision"

ALL STEEL AND STAINLESS STEEL BRAKE LINES SEAL BEST IN BRASS STANDARD INVERT AND BUBBLE FLARE UNIONS





FMSI EDELMANN FITTINGS

THE OFFICIAL TUBE NUT GUIDE





METRIC INVERT/BUBBLE FLARE BLOCK OFF TUBE PLUGS / BRASS UNIONS - STANDARD, BUBBLE, METRIC







BRASS BLOCK OFF TUBE PLUGS

Part # PL141-3	Part # PL141-4	Part # PL141-5	Part # PL141-6
 <p> Tube: 3/16" Thread: 3/8" - 24 Hex: 3/8" Length: 0.535" Seat: Invert Style: Plug </p>	 <p> Tube: 1/4" Thread: 7/16" - 24 Hex: 7/16" Length: 0.545" Seat: Invert Style: Plug </p>	 <p> Tube: 5/16" Thread: 1/2" - 20 Hex: 1/2" Length: 0.620" Seat: Invert Style: Plug </p>	 <p> Tube: 3/8" Thread: 5/8" - 18 Hex: 5/8" Length: 0.650" Seat: Invert Style: Plug </p>

SHORT FEMALE INVERT FLARE TUBE NUTS





Part # 41S-3 141030	Part # 41S-4 141040	Part # 161-4	Part # 41S-5 141050
 <p> Tube: 3/16" Thread: 3/8" - 24 Hex: 7/16" Length: 0.617" Seat: Invert Style: Short Female </p>	 <p> Tube: 1/4" Thread: 7/16" - 20 Hex: 9/16" Length: 0.751" Seat: Invert Style: Short Female </p>	 <p> Tube: 1/4" Thread: 7/16" - 24 Hex: 9/16" Length: 0.750" Seat: Invert Style: Short Female </p>	 <p> Tube: 5/16" Thread: 1/2" - 20 Hex: 5/8" Length: 0.874" Seat: Invert Style: Short Female </p>

SHORT FEMALE INVERT FLARE TUBE NUTS

Part # 41S-6 141060	Part # 41S-8 141080	Part # 141-2	Part # 141-3 121300
 <p> Tube: 3/8" Thread: 5/8" - 18 Hex: 3/4" Length: 0.870" Seat: Invert Style: Short Female </p>	 <p> Tube: 1/2" Thread: 3/4" - 16 Hex: 7/8" Length: 1.00" Seat: Invert Style: Short Female </p>	 <p> Tube: 1/8" Thread: 5/16" - 28 Hex: 5/16" Length: 0.53" Seat: Invert </p>	 <p> Tube: 3/16" Thread: 3/8" - 24 Hex: 3/8" Length: 0.54" Seat: Invert </p> <p>BLF-64</p>

BRASS INVERT FLARE TUBE NUTS

BRASS INVERT FLARE TUBE NUTS

Part # 141-4 121400	Part # 141-5 121500	Part # 141-6 121600	Part # 141-8 121800
 <p> Tube: 1/4" Thread: 7/16" - 24 Hex: 7/16" Length: 0.54" Seat: Invert </p> <p>BLF-65</p>	 <p> Tube: 5/16" Thread: 1/2" - 20 Hex: 1/2" Length: 0.62" Seat: Invert </p>	 <p> Tube: 3/8" Thread: 5/8" - 18 Hex: 5/8" Length: 0.65" Seat: Invert </p>	 <p> Tube: 1/2" Thread: 3/4" - 16 Hex: 3/4" Length: 0.742" Seat: Invert </p>



FMSI EDELMANN FITTINGS

THE OFFICIAL TUBE NUT GUIDE

POSITIVE SEAL BRASS HEAVY DUTY METRIC BUBBLE FLARE UNIONS



Part #	Tube	Thread
3044 276000 (Edelmann) BLU-8(AGS)	3/16"	M10 - 1.0
3047 275300 (Edelmann) BLU-7(AGS)	3/16"	3/8" - 24
4238 277000 (Edelmann) BLU-10(AGS)	1/4"/M6	M12 - 1.0

POSITIVE SEAL BRASS HEAVY DUTY METRIC INVERT FLARE UNIONS



3059 274000 (Edelmann) BLU-9(AGS)	3/16"	M10 - 1.0
3050 274100 (Edelmann)	3/16"	M12 - 1.0
3049	1/4"/M6	M12 - 1.0

BRAKE LINE UNION TEES



Part #	Tube	Thread	Flare
3471 130333(Edelmann) 702 X 3 (W/H)	3/16"	3/8" - 24	Invert
3472 130444(Edelmann) 702 X 4 (W/H)	1/4"	7/16" - 24	Invert
3476 7812 (W/H)	3/16"	3/8" - 24	Invert with Bracket
3722 130222(Edelmann) 702 X 2 (W/H)	1/8"	5/16" - 28	Invert
3723 130555(Edelmann) 702 X 5 (W/H)	5/16"	1/2" - 20	Invert
3724 130666 (Edelmann) 702 X 6 (W/H)	3/8"	5/8" - 18	Invert
4643	3/16"	M10 - 1.0	Invert
4644	3/16"	M10 - 1.0	Bubble/ISO

STANDARD INVERT FLARE BRASS UNIONS



Part #	Tube	Thread
3706 123200 (Edelmann)	1/8"	5/16" - 24
3002 123300 (Edelmann) BLU-3(AGS)	3/16"	3/8" - 24
3005 123400 (Edelmann) BLU-4(AGS)	1/4"	7/16" - 24
3007 123500 (Edelmann) BLU-5(AGS)	5/16"	1/2" - 20
3018 123600 (Edelmann) BLU-6(AGS)	3/8"	5/8" - 18
3021 123800 (Edelmann)	1/2"	3/4" - 18
3020	3/16"	3/8" - 24
	- REDUCER UNION -	
	1/4"	7/16" - 24

FEATURES AND BENEFITS

Corrosion Resistance: Brass is highly resistant to corrosion, which is crucial in automotive applications where parts are exposed to moisture, road salts, and various weather conditions.

Strength and Durability: Brass unions provide a strong and durable connection between components, ensuring reliability and longevity even under harsh conditions.

Temperature Resistance: Brass can withstand a wide range of temperatures without compromising its structural integrity, making it suitable for both engine compartments and undercarriage applications.

Sealing Properties: Brass unions ensure a tight, leak-free connection between tubes and pipes. This is essential for critical application of brake lines.

Ease of Installation and Maintenance: Brass unions are relatively easy to install and dismantle compared to other types of fittings. This facilitates quicker repairs and maintenance, reducing downtime in automotive workshops.

Compatibility: Brass is compatible with various automotive fluids and fuels, including oil, coolant, and **brake fluid**.

FMSI EDELMANN FITTINGS

THE OFFICIAL TUBE NUT GUIDE

MASTER CYLINDER ADAPTERS INVERT/BUBBLE



A MASTER CYLINDER ADAPTERS INVERT



INVERT



A



INVERT

Part #	Tube(F)	Thread(F)	Tube(M)	Thread(M)
3230 258350(Edelmann) 7909(W/H)	3/16"	3/8" - 24	5/16"	1/2" - 20
3231 258303(Edelmann) 7910(W/H)	3/16"	3/8" - 24	3/16"	9/16" - 20
3232 258340(Edelmann) 7818(W/H)	3/16"	3/8" - 24	1/4"	7/16" - 24
3237 258302(Edelmann) 7911(W/H)	3/16"	3/8" - 24	3/16"	9/16" - 18
3285	3/16"	3/8" - 24	3/16"	3/8" - 24
4601 258307(Edelmann) 7913(W/H)	3/16"	1/2" - 20	3/16"	9/16" - 18
4602 258306(Edelmann) 7912(W/H)	3/16"	9/16" - 18	3/16"	1/2" - 20
3233 258450(Edelmann) 7829(W/H)	1/4"	7/16" - 24	1/4"	1/2" - 20
3235 258430(Edelmann) 7828(W/H)	1/4"	7/16" - 24	3/16"	3/8" - 24
3236 258403(Edelmann) 7908(W/H)	1/4"	7/16" - 24	1/4"	9/16" - 18
3418 258560(Edelmann) 7916(W/H)	5/16"	1/2" - 20	3/8"	5/8" - 18
4603 258540(Edelmann) 7917(W/H)	5/16"	1/2" - 20	1/4"	7/16" - 24
3419 258650(Edelmann) 7915(W/H)	3/8"	5/8" - 18	5/16"	1/2" - 20

A 1/4" (M6) METRIC INVERT TO METRIC INVERT

Part #	Tube(F)	Thread(F)	Tube(M)	Thread(M)
4639 270309(Edelmann)	1/4"/M6	7/16" - 24	1/4"/M6	M12 - 1.0
4640 270310(Edelmann)	1/4"/M6	7/16" - 24	1/4"/M6	M12 - 1.5
4641 270307(Edelmann)	1/4"/M6	7/16" - 24	1/4"/M6	M10 - 1.0

B 3/16" INVERT TO METRIC BUBBLE FLARE



INVERT



B



BUBBLE

Part #	Tube(F)	Thread(F)	Tube(M)	Thread(M)
3039 271300(Edelmann) 1442(W/H)	3/16"	3/8" - 24	3/16"	M10 - 1.0
3250 270330(Edelmann) 7970(W/H)	3/16"	3/8" - 24	3/16"	M10 - 1.25
3251 263000(Edelmann) 7972(W/H)	3/16"	3/8" - 24	3/16"	M13 - 1.5
3252 265000(Edelmann) 7974(W/H)	3/16"	3/8" - 24	3/16"	M12 - 1.0
3253 264000(Edelmann) 7935(W/H)	3/16"	3/8" - 24	3/16"	M11 - 1.5
4612	3/16"	3/8" - 24	3/16"	M11 - 1.25
4613	3/16"	3/8" - 24	3/16"	M12 - 1.25
4616	3/16"	3/8" - 24	3/16"	M11 - 1.0
4619	3/16"	3/8" - 24	3/16"	M10 - 1.5
4654	3/16"	3/8" - 24	3/16"	M14 - 1.5

A 3/16" INVERT TO METRIC INVERT

Part #	Tube(F)	Thread(F)	Tube(M)	Thread(M)
3045 270300(Edelmann) 1443(W/H)	3/16"	3/8" - 24	3/16"	M10 - 1.0
3479 270330(Edelmann) 7976(W/H)	3/16"	3/8" - 24	3/16"	M10 - 1.25

B 1/4" INVERT TO METRIC BUBBLE FLARE

Part #	Tube(F)	Thread(F)	Tube(M)	Thread(M)
4614	1/4"/M6	7/16" - 24	1/4"	M12 - 1.25
4615	1/4"/M6	7/16" - 24	1/4"	M12 - 1.75
4650	1/4"/M6	7/16" - 24	1/4"	M12 - 1.5
4617	1/4"/M6	7/16" - 24	1/4"	M11 - 1.0
4618	1/4"/M6	7/16" - 24	1/4"	M14 - 1.5
4642	1/4"/M6	7/16" - 24	1/4"	M12 - 1.0



FMSI EDELMANN FITTINGS

THE OFFICIAL TUBE NUT GUIDE

BRASS ADAPTERS - STANDARD • METRIC • PIPE THREAD • SURFACE SEAL

B 3/16" INVERT TO METRIC BUBBLE FLARE

Part #	Tube(F)	Thread(F)	Tube(M)	Thread(M)
3255	3/16"	3/8" - 24	3/16"	3/8" - 24
3478	3/16"	3/8" - 24	3/16"	1/2" - 18
4607	3/16"	3/8" - 24	1/4"	7/16" - 20

B 3/16" METRIC INVERT TO METRIC BUBBLE

Part #	Tube(F)	Thread(F)	Tube(M)	Thread(M)
4627	3/16"	M10 - 1.0	3/16"	M10 - 1.0
3473	3/16"	M10 - 1.0	3/16"	M11 - 1.5
<small>7935(W/H)</small> 3474	3/16"	M10 - 1.0	3/16"	M12 - 1.0
<small>7936(W/H)</small> 3475	3/16"	M10 - 1.0	3/16"	M13 - 1.5
<small>7937(W/H)</small>				

C 3/16" METRIC BUBBLE TO METRIC BUBBLE



Part #	Tube(F)	Thread(F)	Tube(M)	Thread(M)
3254	3/16"	M10 - 1.25	3/16"	M13 - 1.5
4606	3/16"	M10 - 1.0	3/16"	M13 - 1.5
<small>268000(Edelmann)</small> 4604	3/16"	M10 - 1.0	3/16"	M11 - 1.5
<small>266000(Edelmann)</small> 4605	3/16"	M10 - 1.0	3/16"	M12 - 1.0
<small>267000(Edelmann)</small> 4630	3/16"	M10 - 1.0	3/16"	M10 - 1.5
4631	3/16"	M10 - 1.0	3/16"	M12 - 1.25
4632	3/16"	M10 - 1.0	3/16"	M10 - 1.25
4633	3/16"	M10 - 1.0	3/16"	M11 - 1.0

C 1/4" (M6) METRIC BUBBLE TO METRIC BUBBLE

Part #	Tube(F)	Thread(F)	Tube(M)	Thread(M)
4634	1/4"/M6	M12 - 1.0	1/4"/M6	M12 - 1.5
4635	1/4"/M6	M12 - 1.0	1/4"/M6	M14 - 1.5
4636	1/4"/M6	M12 - 1.0	1/4"/M6	M12 - 1.25
4637	1/4"/M6	M12 - 1.0	1/4"/M6	M12 - 1.75
4638	1/4"/M6	M12 - 1.0	1/4"/M6	M11 - 1.0

D 3/16" INVERT TO SURFACE SEAL



Part #	Tube(F)	Thread(F)	Tube(M)	Thread(M)
4609	3/16"	3/8" - 24	3/16"	1/2" - 20
<small>265301(Edelmann) 7817(W/H)</small>				
3029	1/4"	7/16" - 24	1/4"	7/16" - 20
<small>265400(Edelmann) 7732(W/H)</small>				
3233	1/4"	7/16" - 24	1/4"	1/2" - 20
<small>265401(Edelmann) 7727(W/H)</small>				
4611	5/16"	1/2" - 20	5/16"	1/2" - 20
<small>265500(Edelmann) 1074(W/H)</small>				
4653	5/16"	1/2" - 20	3/16"	3/8" - 24

E INVERT TO PIPE THREAD



Part #	Tube(F)	Thread(M)	Edelmann	W/H
4623	1/8"	1/8	124220	202x2
3481	3/16"	1/8	124320	202x3
3482	1/4"	1/8	124420	202x4
3483	1/4"	1/4	124440	202x4x4
3484	5/16"	1/8	124520	202x5
3485	5/16"	1/4	124540	202x5x4
3486	3/8"	1/4	124640	202x6
3707	3/8"	1/8	124620	202x6x2
3708	3/8"	3/8	124660	202x6x6
3709	1/2"	3/8	124860	202x8
4852	1/2"	1/2	124880	202x8x8

FMSI EDELMANN FITTINGS

THE OFFICIAL TUBE NUT GUIDE

POWER STEERING & TRANSMISSION ADAPTERS • STEEL COMPRESSION UNION



POWER STEERING & TRANSMISSION ADAPTERS



3466



3467



3468



3469



4624

Part #	Female(Invert F)	Male
3466	3/8" Tube (5/8" Thread)	16mm x 1.5 GM
3467	3/8" Tube (5/8" Thread)	14mm x 1.5 GM
3468	3/8" Tube (5/8" Thread)	18mm x 1.5 GM
3469	3/8" Tube (5/8" Thread)	11/16" - 18 Ford
4624	3/8" Tube (5/8" Thread)	5/8" - 18 Bubble Flare

HEAVY DUTY HIGH PRESSURE STEEL COMPRESSION UNION

UP TO 1200PSI WORKING PRESSURE - 5000PSI BURST PRESSURE



3451



COMPRESSION UNION COMPONENTS



3461

Part #	Tube Size	Thread	Working Pressure	Burst Pressure
3451	3/16"	3/8" - 24	1200	5000
3452	1/4"	7/16" - 24	1200	5000
3453	5/16"	1/2" - 20	1000	4000
3454	3/8"	9/16" - 18	1000	4000
3459	10mm	9/16" - 18	1000	4000
3460	12mm	16mm - 1.0	1000	4000
3461	3/8" x 10mm	9/16" - 18 / 14mm - 1.0	1000	4000

- REDUCER -

BRASS invert and bubble flare unions offer the best malleable sealing surface and corrosion protection.





FMSI EDELMANN FITTINGS

THE OFFICIAL TUBE NUT GUIDE

INDEX - INTERCHANGE /FMSI/EDELMANN/AGS

INTERCHANGE /FMSI/EDELMANN/AGS

FMSI Part #	EDELMANN Part #	AGS Part #	PG #	FMSI Part #	EDELMANN Part #	AGS Part #	PG #	FMSI Part #	EDELMANN Part #	AGS Part #	PG #
141-2			9	3417	121050	BLF-40	3	4602	258306		11
141-3	121300	BLF-64	9	3418	258560		11	4603	258540		11
141-4	121400	BLF-65	9	3419	258650		11	4604	266000		12
141-5	121500		9	3420	276110	BLF-39	5	4605	267000		12
141-6	121600		9	3421	276015	BLF-51	6	4606	268000		12
141-8	121800		9	3422	276017	BLF-52	6	4607			12
161-4			9	3423	276017	BLF-53	6	4609	265301		12
3000	121003	BLF-12B	2	3424	121003		2	4611	265500		12
3000SS		BLSF-12	4	3426			6	4612			11
3001	121030	BLF-10	2	3433			6	4613			11
3001SS		BLSF-10	4	3434	109600	PSR-016	7	4614			11
3002	123300	BLU-3	10	3435			7	4615			11
3003	121004	BLF-13	2	3436	109800		7	4616			11
3004	121040	BLF-16C	2	3438		PSR-017	7	4617			11
3004SS		BLSF-16	4	3439	121072	BLF-41	3	4618			11
3005	123400	BLU-4	10	3441	121003		2	4619			11
3006	121005	BLPF-14	2	3442		PSR-013	2	4623			12
3006SS		BLSF-14	4	3443		PSR-014	7	4624			13
3007	123500	BLU-5	10	3445			7	4627			12
3008	121070	FLR-008	7	3447			6	4630			12
3009	121069	FLR-009	7	3448			7	4631			12
3015	121006	BLF-15	2	3449			5	4632			12
3015SS		BLSF-15	4	3451			13	4633			12
3016			2	3452			13	4634			12
3018	123600	BLU-6	10	3453			13	4635			12
3020			10	3454			13	4636			12
3021	123800		10	3459			13	4637			12
3022	121034	BLF-11C	3	3460			13	4638			12
3022SS		BLSF-11	4	3461			13	4639			11
3023	121072	BLF-41	3	3462	121049		3	4640			11
3023SS		BLSF-41	4	3463			5	4641			11
3024	121039	BLF-42	3	3464		PSR-018	7	4642			11
3024SS		BLSF-42	4	3466			13	4643			10
3025	121049	BLF-43	3	3467			13	4644			10
3025SS		BLSF-43	4	3468			13	4650			11
3026	121045	BLF-44	3	3469			13	4653			12
3026SS		BLSF-44	5	3470			5	4654			11
3028	276010	BLPF39	5	3471	130333		10	4852			12
3028SS		BLSF-39	5	3472	130444		10	6800			4
3029	265400		12	3473			12	6801			7
3039	271300		11	3474			12	6810SS			4
3040	276011	BLF-47	6	3475			12	6802	109400		7
3041	276012	BLF-48	6	3476			10	6803	121069		4
3041SS		BLSF-48	5	3477	121073		5	6805			7
3042	276013	BLF-49	6	3478			12	6806			7
3043	121071	BLF-40	3	3479	270330		11	6807			8
3043SS		BLSF-40	5	3481			12	6808			2
3044	276000	BLU-8	10	3482			12	6810	121035		3
3045	270300		11	3483			12	6810SS			4
3047	275300	BLU-7	10	3484			12	6811			3
3049			10	3485			12	6812			4
3050	274100		10	3486			12	6813			4
3059	274000	BLU-9	10	3487			7	6814			2
3230	258350		11	3488			7	6815			8
3231	258303		11	3489			2	6816			8
3232	258340		11	3490			6	6817			8
3233	258450		11/12	3492			5	6818			8
3235	258430		11	3493			6	6825			8
3236	258403		11	3494			3	6826			8
3237	258302		11	3495			6	6827			8
3250	270330		11	3496			6	6828			8
3251	263000		11	3597	121002		2	6829	120300	BLF-60	8
3252	265000		11	3706	123200		10	6830	120400		8
3253	264000		11	3707			12	6831			8
3254			12	3708			12	6832			8
3255			12	3709			12	6840			3
3285	258302		11	3722	130222		10	6841			3
3399			2	3723	130555		10	6842			5
3407	121074		3	3724	130666		10	6843			2
3408			6	41S-3	141030	BLF-102	9	6844			5
3409			3	41S-4	141040	BLF-103	9	6850			8
3410	276014	BLF-38	5	41S-5	141050		9	PL141-3			9
3411	276110		5	41S-6	141060		9	PL141-4			9
3413	276015	BLF-46	6	41S-8	141080		9	PL141-5			9
3414	276110		5	4238	277000	BLU-10	10	PL141-6			9
3415	121004		2	4601	258307		11				



BULK COILS - 3000' TO 5000' LENGTH



Available in ... 3/16" - 1/4" - 5/16" - 3/8"
6mm

COPPERHEAD 90/10 CUPRO NICKEL TUBING

Copperhead lines - S.A.E. J1047, J1677, J1650 and ISO 4038

SILVERBACK 304 STAINLESS STEEL TUBING

Silverback Stainless lines - 304 / ASTM A269

RHINOHIDE (PVF) POLYMER VINYL FLUORIDE GREEN

Rhinohide lines are Copper coated I.D./O.D. Easy to bend plated Zinc & PVF 15 - 20 UM O.D.

SILVER ZINC

Zinc Shield lines are Copper coated I.D./O.D. Easy to bend plated Zinc

BULK LINES - 3000' TO 5000' LENGTH

PROUDLY FABRICATED IN NORTH AMERICA SINCE 1995

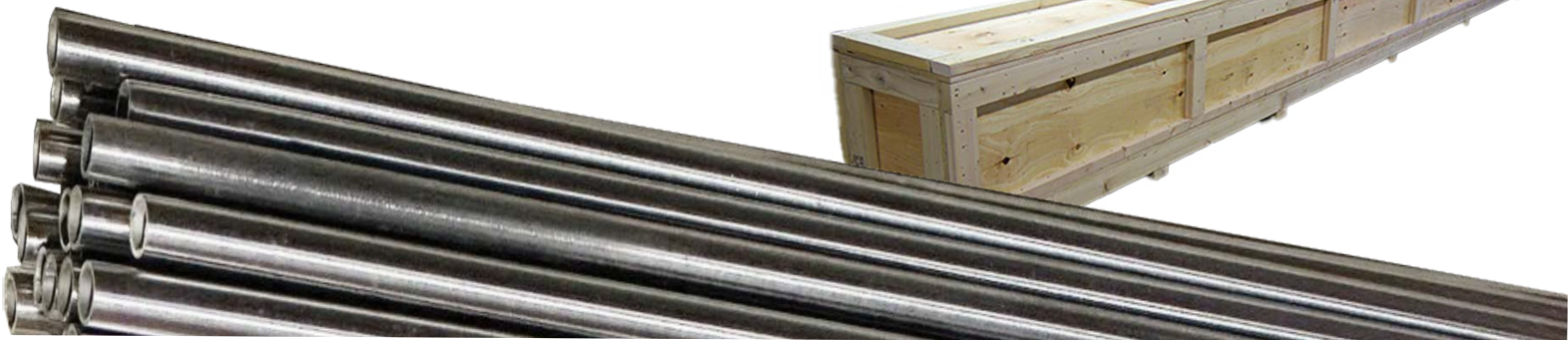



FMSI EDELMANN FITTINGS
 THE OFFICIAL TUBE NUT GUIDE

YOUR SOURCE FOR BULK TUBING

- 16' & 20' Straight lengths
- Bulk Coils - 3000' to 5000' length
- Quality Brake Lines 8" - 84"



**90/10 CUPRO NICKEL
 STAINLESS STEEL
 POLYMER VINYL FLUORIDE
 SILVER ZINC**

CUPRO NICKEL

SILVER ZINC

PVF

STAINLESS STEEL

PROUDLY FABRICATED IN NORTH AMERICA SINCE 1995

BULK LENGTHS

BULK LENGTHS



**Have questions about BRAKE LINES?
 WE'RE YOUR GO-TO SOURCE FOR BRAKE LINE EXPERTISE.**

CANADA OFFICE: 1070 HERITAGE ROAD, BURLINGTON, ON L7L4X9
 TOLL FREE: 800.651.7445 • FAX: 905.335.1829 • EMAIL: INFO@FMSIINC.COM • WEBSITE: FMSIINC.COM



MAR25